



Pulsar® System

OPERATOR'S MANUAL



Model # PS-500

Product Stewardship

MAKING THE WORLD A BETTER PLACE



Lonza is committed to maintaining and improving our leadership in the stewardship of our products. One of our initiatives is to make health, safety, and environmental protection an integral part of a product's life cycle – from manufacture, marketing, and distribution to use, recycling, and disposal.

Everyone involved with the product has responsibilities to address society's interest in a healthy environment and in products that can be used safely. We are each responsible for providing a safe workplace. All who use and handle products must follow safe and environmentally sound practices.

For more information about our Product Stewardship Program, contact your Lonza Representative. For product inquiries, contact 1-800-4PULSAR or pulsar@lonza.com.

Dealer Contact:

The Major Components - How They Work

General Principles of Operation

The three main components of the **Pulsar® 500 Feeder** are (from top to bottom) the Briquette Hopper, the manifold spray section and the discharge tank. The water from the pool enters the **Pulsar® 500 Feeder** via the inlet port. The spray manifold then distributes the water onto the briquette grid creating a chlorinated solution. The chlorinated solution falls into the discharge tank and is discharged into the pool recirculation system by the evacuation system.

The amount of chlorine discharged from the feeder is determined by an external chemical controller or the Timer. **When using an ORP controller with this unit, select “External Signal” for the ORP or “Feed Rate Timer” to use the internal Timer.**

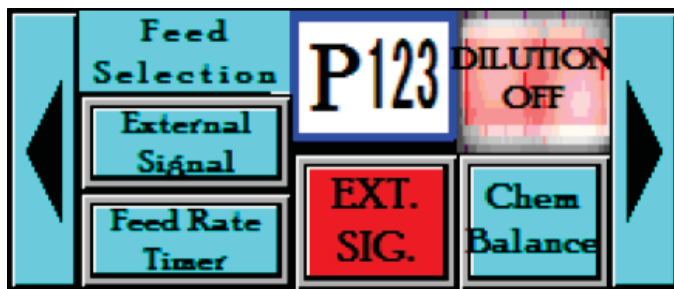

Inlet water pressure of 35 to 45 psi [2.41-3.10 bar] is required to provide sufficient flow into the **Pulsar® 500**. These pressures will result in an inlet flow of 2.25 gallons/minute [8.52 lpm]. The **Pulsar® 500** feed rate settings referred to in the Pulsar® System Owners manual (right) are calibrated for this flow rate.

Flow out of the **Pulsar® 500** discharge tank requires a vacuum to drain. A minimum outlet flow-rate of 2.5 gal/minute [9.46 lpm] ensures that the flow out of the **Pulsar® 500** exceeds the flow in. Once the **Pulsar® 500** is installed, outlet flow can be measured by watching the level in the bottom tank. If the level is rising as the feeder is running, there is insufficient flow out.

Figures in Chart below represent Feeder Output in Pounds of Available Chlorine per Day

Using the arrows on the touch screen, set the timer to the desired “% output rate”

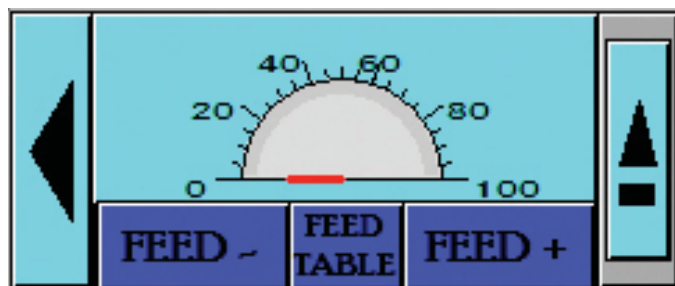

% output rate	lbs [kg] Av. Cl
100	486 [220.4]
95	462 [209.4]
90	437 [198.4]
85	413 [187.4]
80	389 [176.4]
75	365 [165.3]
70	340 [154.3]
65	316 [143.3]
60	292 [132.3]
55	267 [121.2]
50	243 [110.2]
45	219 [99.2]
40	194 [88.2]
35	170 [77.2]
30	146 [66.1]
25	122 [55.1]
20	97 [44.1]
15	73 [33.1]
10	49 [22.0]
5	24 [11.0]
0	0 [0.0]

SPECIFICATIONS – Model PS-500

Operational Requirements:

Inlet pressure (Range)	35-45 psi [2.41-3.10 bar]
Ideal	37 psi [2.55 bar]
Outlet vacuum	15-29" Hg. [38.1-73.7cm]
Operating Temperature	40-115°F [4.4° to 46.1° C]
Supply power	110V, 15A (NEMA 5-15R)

Operational Characteristics:

Inlet flow	2.25 gpm [8.52 lpm]
Outlet flow	2.5 gpm [9.46 lpm]

Dimensions:

Tubing	1/2" [12.7mm] O.D. Polyethylene
Feeder dimensions	W: 43" [109.2cm] x D: 52" [132.1cm]
Feeder height	40" [101.6cm]
Feeder weight (full)	465 lbs [210.9kg]
Feeder weight (empty)	165 lbs [74.8kg]

Capacity:

300 lbs [136.1kg] Pulsar® Plus Briquettes (equivalent to 204 lbs [92.5kg] available chlorine)

Feed Rate:

Pulsar® Plus Briquettes: 24-486 lbs [11.0-220.4kg] of Available Chlorine per day

Hopper Fill Increments:

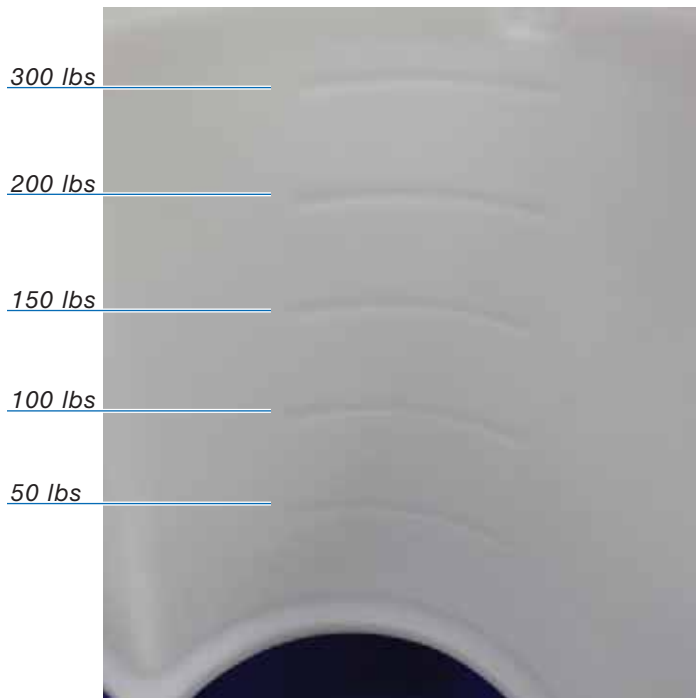

Recommended Pool Size¹:

50,000-600,000 gallon [189,270-2,271,250 liter] un-stabilized¹

100,000-1,800,000 gallon [378,541-6,813,750 liter] stabilized¹

¹Subject to local health codes

General Principles of The Pulsar® 500

Components

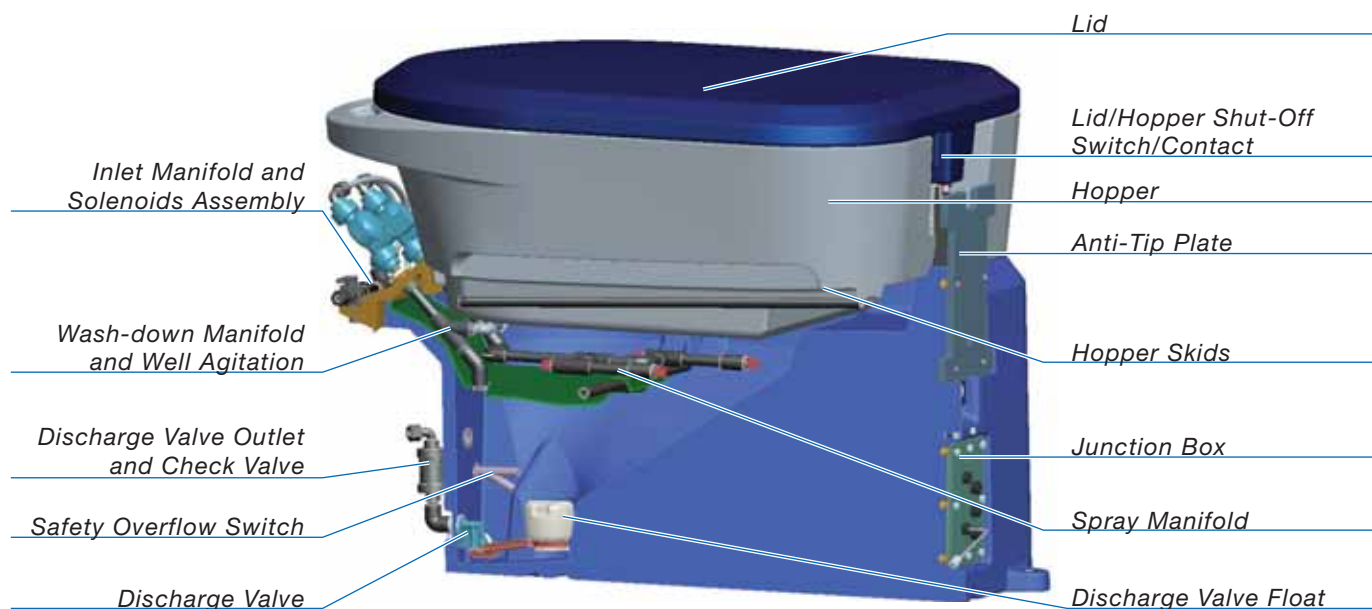

The **Pulsar® 500** employs an “HMI/PLC” electronics package for efficient operation and enhanced safety features. The power to the feeder is reduced to 24VDC with the use of a step-down transformer in the control panel. The **Pulsar® 500** utilizes a PLC Timer with 21 presets for 0-100% control of chlorine output rates. Additionally, Safety Switches are used to interrupt spray to the



nozzles when the lid is opened or when the hopper is removed. The **Pulsar® 500** also incorporates improved maintenance features. Water flow in the unit is designed to remove residue from the feeder base. Listed below is a description of each component of the Electronics Package:

Lid Safety Switch:

The **Pulsar® 500** is equipped with a Lid Safety Switch. This switch will interrupt flow to the spray jets when the lid is opened. The design of this feature incorporates a proximity switch so there are no wires connecting the lid to the feeder hopper or the hopper to the base. When the hopper is separated from the feeder base, power to the solenoid is turned off.



General Principles of The Pulsar® 500

Safety Overflow Switch:

The **Pulsar® 500** utilizes a Safety Overflow Switch to prevent the unit from overflowing. Outlet flow can be slowed or stopped by many causes, which can ultimately lead to the unit overflowing. The most common cause would be scale buildup in the venturi, discharge valve and/or outlet tubing. The electronic overflow switch will interrupt power to the solenoid if the level in the discharge tank reaches a set height. When power is interrupted, the solenoid will close and shut off the inlet flow to the spray manifold. The switch, when triggered, also energizes the booster pump.



Solenoid/Timer Assembly:

The **Pulsar® 500** relies on a control panel with internal timer and solenoid to control output rate. The Pulsar® Control Panel uses a 120V power supply (plug in control panel to dedicated 15A circuit breaker) and the solenoid uses a 24VDC power supply (powered by the control panel). The **Pulsar® 500** can also be used in conjunction with an ORP controller. The yellow male pigtail from the **Pulsar® 500** controller should be plugged into the 120V chlorine pigtail of the ORP controller. The signal from the ORP controller will be relayed to the solenoid to feed chlorine.



Pulsar® Control Panel

ORP Controller

Chlorine Pigtail

General Principles of The Pulsar® 500

Test Operation of Electronic Switches:

Note: Close inlet and outlet valves.

Before start up, lift the briquette screen out of the hopper and set aside on a clean surface. Plug the power cord from the **Pulsar® 500** controller into a dedicated 15amp GFCI outlet. The touchscreen should be blinking. Lift the hopper off the base. The lid alarm light will come on. This indicates that the lid switch is working properly.



Next, with the hopper off, remove the valve plate and manifolds and place off to the side. Remove the shield and place to the side. Reach into the base and lift the safety overflow switch. An alarm page for High Level should pop up, indicating that the switch is working properly. Replace the shield, valve plate with manifolds and place the hopper on the base. Next lift the lid. The lid alarm light should come on.

This concludes the test procedure. Should the test procedures fail, refer to the Electrical and Control Panel Set-up section (pages 12-14) for more information or contact your Dealer for additional information.

Safety Features

Overflow Port:

In the event that the solenoids fail to close, an overflow port has been incorporated into the **Pulsar® 500** design. PVC pipe should be run from this overflow port to a retention area. The solenoid should be checked when an abnormally low or high chlorine reading is indicated in the pool or when water is flowing out of the overflow port through the pipe down to the drain.



Overflow Port

Unplug the controller from the outlet or ORP unit and call the dealer. If water continues to flow into the feeder, the solenoid is stuck open or water is backflowing through outlet piping.

If flow stops when the controller is unplugged, the problem is the electronic overflow switch, or outlet piping allowing water to backflow into feeder. In either situation, the inlet/outlet ball valve should be closed and the dealer should be contacted for assistance.

General Principles of The Pulsar® 500

Maintenance Features

Well Agitator:

The Well Agitator is designed to keep solids in suspension for removal with the suction created from the venturi. The Well Agitator nozzle can become blocked over time. Remove the well agitator nozzle and clean nozzle orifice if needed. Refer to Appendix A for modifications to the Well Agitator.



Drain Port:

The Drain Port is used to clean excess residue and scale buildup from the feeder discharge tank. Remove the 3/4" [19mm] plug and flush system as needed.



Drain Port

Wash-down & Shield:

Below is a picture of the shield and wash-down manifold assembly. This assembly is designed to wash loose solids into the base where they are removed with the chlorine solution. Refer to Appendix A for modifications to the wash-down nozzle.

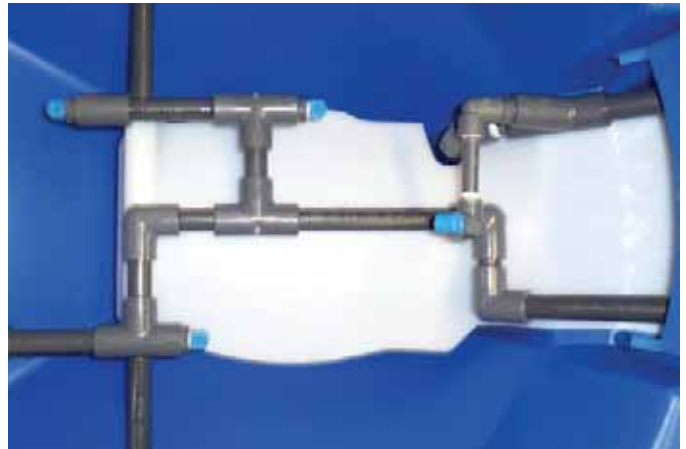

The shield protects the valve, float and electronic level switch from scale and residue deposits.

Without this shield, scale and residue will increase float weight and decrease buoyancy. In addition, scale buildup can bind pivot points, which could result in valve failure.

Pre-Startup Checklist

Following the procedure outlined below will ensure a smooth start-up of the **Pulsar® 500 Feeder**. For seasonal operation, perform this procedure each spring.

IMPORTANT!!

Do NOT put Pulsar® Plus Briquettes in the feeder during the start-up operation.

Inlet Water Flow

The inlet water flow system is designed to provide a steady side-stream of clean filtered pool water to the feeder.

1. Switch on pool recirculation system, then open valves associated with feeder (suction/discharge valves). Then start Booster pump. **MAKE SURE BOOSTER PUMP VALVES TO SUCTION AND DISCHARGE ARE OPEN TO PREVENT DEAD HEADING.**
2. With lid open, place a metal object over the lid switch to see that the four nozzles are spraying water onto the Briquette-Tank grid.
3. Check all lines leading to the feeder for leaks. Hand tighten all fittings if any leaks are found.
4. Check to make sure Safety Overflow Switch is oriented properly with the float below the switch.

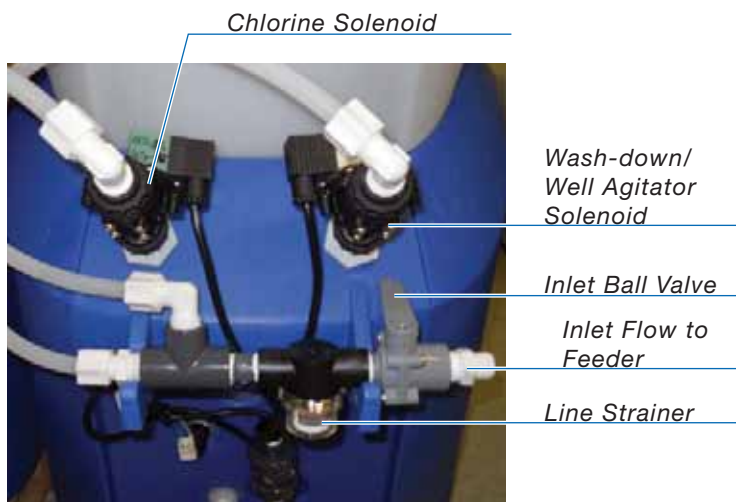

Outlet Water Flow

As the Discharge Tank fills with water, the float on the Discharge Valve rises with the water level and allows the pump suction to draw the chlorinated water into the pool's recirculation system. When the water level drops, the float falls, shutting off the valve. There is a Check Valve mounted vertically on the Discharge Valve to prevent pool water from backing up into the Discharge Tank.

Use the following procedure to ensure that the outlet flow system is operating properly.

1. With the Briquette Hopper of the feeder temporarily off the discharge tank, use a hose or pail to fill the Discharge Tank with sufficient water to open the Discharge Valve.
2. The float should rise, opening the Discharge Valve, allowing water to be drawn out by the **Pulsar®** evacuation system.
3. Check the system for leaks. If small air bubbles are visibly moving, there may be an air leak. Tighten the connectors and make sure that the O-ring is properly installed in the fittings. (NOTE: Air bubbles near the **Pulsar® 500 Feeder** body that do not move are normal and do not indicate leaks.)
4. Tighten connections on check valve true union fittings and Tubing nut on Parker fitting. Refer to Appendix B for more information on check valve orientation.



Startup Procedures

After completing the PRE-START-UP CHECKLIST, and establishing that all components of the feeder are operating properly, your **Pulsar® 500 Feeder** is ready for start-up.

Routine maintenance of the **Pulsar® 500 Feeder** is minimized when proper pool water balance is maintained. Maintain pool water chemistry as follows:

Total Alkalinity	60 - 80ppm
Calcium Hardness	200 - 1800ppm
PH	7.2 - 7.6
LSI	-0.3 - +0.5

On the ORP screen, there is a button for “Chem Balance” which will calculate the Langelier Saturation Index given the user input values for TA, pH, Hardness, Temperature and TDS.

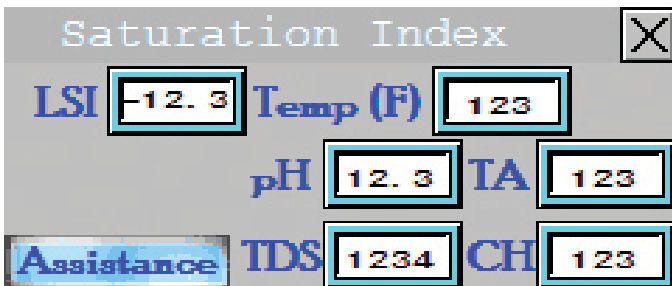

Adherence to these recommendations at all times will ensure the most effective and economical performance from the **Pulsar® 500 Feeder**.

NOTE: The use of Carbon Dioxide gas (CO₂) to lower pH will raise the Total Alkalinity significantly. High total alkalinity (over 80 ppm) will increase scale and solids buildup in feeder.

WARNING

The **Pulsar® 500 Feeder** can only be installed with the **Booster Pump, Venturi and Flow switch** provided with the unit. These components, combined with the **Booster pump interlock** with the main pool pump, will prevent high levels of chlorine in the pool after **Pool pump shut-down**.

DANGER: Under no circumstances should you mix calcium hypochlorite with other forms of concentrated chlorine or other chemicals. Fire and/or explosion may result. Caution must be used when refilling dispenser.

KEEP OUT OF REACH OF CHILDREN

1. Fill the Briquette Hopper with **Pulsar® Plus Briquettes**. The Briquette Hopper holds 300 pounds [136.1kg] of **Pulsar® Plus Briquettes**.
2. Check the chart on page 11 to determine an approximate start-up timer setting for your pool.
3. Open all valves to the pool and to the feeder.
4. Monitor the water flow to the feeder daily to ensure that a proper flow is being maintained.
5. During the first few days of operation, check chlorine level in the pool frequently to establish the best Timer setting (or ORP Controller setting) for your pool. Adjust the chlorine output either up or down according to the table or, adjust the ORP set-point.

WARNING

Always monitor the free chlorine residual in the pool water per the health code requirements. If the FAC level exceeds acceptable levels, do not enter the pool until the residual is in the acceptable range.

Startup Procedures

RECOMMENDED START-UP SETTINGS

*Do not exceed 25-ppm stabilizer

Control Panel Feed Rate	Pool Volume (Gallons [Liters])	
	Stabilized Pool	Un-Stabilized Pool
% Output		
100	N/A	N/A
95	N/A	N/A
90	N/A	N/A
85	N/A	N/A
80	N/A	N/A
75	N/A	N/A
70	N/A	N/A
65	N/A	N/A
60	N/A	N/A
55	N/A	N/A
50	N/A	N/A
45	N/A	N/A
40	2,000,000 [7,570,000]	666,667 [2,523,333]
35	1,750,000 [6,623,750]	583,333 [2,207,917]
30	1,500,000 [5,677,500]	500,000 [1,892,500]
25	1,250,000 [4,731,250]	416,667 [1,577,083]
20	1,000,000 [3,785,000]	333,333 [1,261,667]
15	750,000 [2,838,750]	250,000 [946,250]
10	500,000 [1,892,500]	166,667 [630,833]
5	250,000 [946,250]	83,333 [315,417]
0	0 [0]	0 [0]

Pulsar® 500 Startup Procedure: Control Panel

Electrical and Control Panel Set-up

Starting Up The System For The First Time

When you first power on the control panel, you should see this screen. Tap once on the screen to go to the main control page.



The control screen is the main screen for the system, and the one that you will see when running normally.



1. NO FLOW – This is your flow indication. When RED, no flow is being detected by the flow switch. When GREEN, flow is good and the system will be allowed to run.
2. PUMP OFF – This indicates the state of the booster pump start signal.
3. FEED OFF – This indicates the state of the FEED valve.
4. WASH OFF – This indicates the state of the WASH valve.

5. ALARM SCREEN – This is a signal light as well as a button. When pressed, the Alarm page is brought up. This will show you your active alarms as well as an alarm history of all alarms that are not acknowledged. It will also allow you to troubleshoot alarms directly from that page. Instructions are included for troubleshooting on the screen.

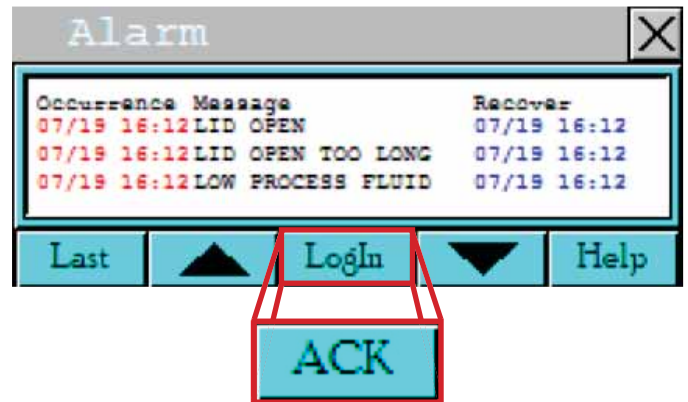

6. E-STOP OK – This is a button which will turn off all outputs when pressed. (The PUMP will turn OFF, the FEED and WASH valves will CLOSE).
7. FEED START – This button toggles the feed process, ON or OFF.
8. PULSAR CRS™ & WASH TIMERS – This button goes to the WASH TIMER page where you can set up the after-feed wash time, and access the idle feeder wash settings. You can also enter the Pulsar CRS™ system programming screen.
9. SET UP – This page goes to the system set up pages. All settings on following pages should be set up initially, then verified after any power outage.

Pulsar® 500 Startup Procedure: Control Panel

Power Up Programming Directions

1. When powered up for the first time, tap anywhere on the **Pulsar®** logo screen (*figure 1*) to reach the main screen (*figure 2*).
2. On the main screen (*figure 2*), press 'CRS & WASH TIMERS' to set up the timers, as well as the idle feeder wash settings.
3. On the wash screen (*figure 3*), press the UP and DOWN arrows next to the wash timer readout to raise or lower the wash by one minute. (Default is 5 minutes. Minimum is 1 minute. Maximum is 30 minutes.)
 - a. Skip steps 4 & 5 if a CRS system is not installed.
 - b. Go to Appendix C if a CRS system will be installed.
4. On the wash screen (*figure 3*), press 'CRS' to enter the **Pulsar CRS™** System programming screen (*figure 4*) and (after initial 'LOG IN') press the right arrow to enter the idle feeder wash screen (*figure 5, page 14*). **Both need to be setup for the feeder to function properly.**
5. On the **Pulsar CRS™** System programming screen (*figure 4*), input the pool size in gallon. If **Pulsar CRS™** Clarifier is in use, it is necessary to press 'CRS SETUP', then select from the popup options (*figure 6, page 14*).
6. To program the idle feeder wash screen (*figure 5, page 14*), it is necessary to set the timers for proper operation of the feed and wash spray during times of non-use. The idle feeder wash (min) is the delay time from the time of the last operation of the feed or wash spray to when the feeder is considered Idle, and will Wash and/or Feed to keep the basin moist. Minimum value is 1, Maximum is 300. The Wash Timer (min) is the same as the wash timer on the wash screen.



figure 1



figure 2



figure 3



figure 4

Pulsar® 500 Startup Procedure: Control Panel

Power Up Programming Directions (cont'd)

- After programming the idle feeder wash, the rest of the feeder settings need to be engaged. From the main screen (figure 2, page 13), press 'SET UP' to enter the feed selection screen (figure 7). The feeder signal must be set up for either external signal or feed rate timer to engage the chlorinator feed cycle. If neither are green, please select the feeder control type desired. (figures 8, at right and figure 9, page 15).
- Figure 8 shows that an external signal (i.e. from either an ORP or chlorine controller) will control the feed. When the Pulsar® control panel received a signal from an external source, it will engage the feed cycle.
- Figure 9 (page 15) shows that the internal feed rate timer has been selected, and now the feed rate dial page (figure 10, page 15) is available to dial up or down the chlorine to the desired setpoint.
- Figure 10 (page 15) shows the feed rate dial. Pressing 'FEED -' or 'FEED +' will decrease or increase the feed rate in increments of 5%, from 0% to 100%. The red line indicates the current feed rate percentage. The 'FEED TABLE' button opens a table (figure 11, page 15) which correlates the feed rate percentage to a pounds per day of chlorine, based on 24 hours. If this button does nothing, then the feeder model size needs to be set up (figure 12, page 15). The 'Arrow Bar' button on the right of the screen returns the operator to the main control screen.
- Figure 11 (page 15) is the feed table for a given feeder. It correlates the feed rate percentage on the previous screen to a pounds per day usage. The table shown is specific to the Pulsar® 140 Feeder. Close the window by pressing the 'X' in the top right. This will return to the feed rate dial screen.

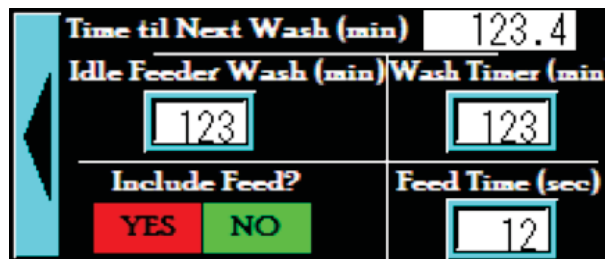

figure 5

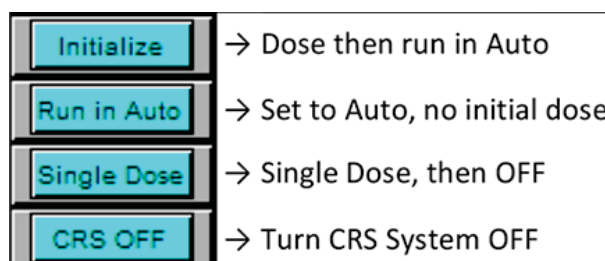

figure 6

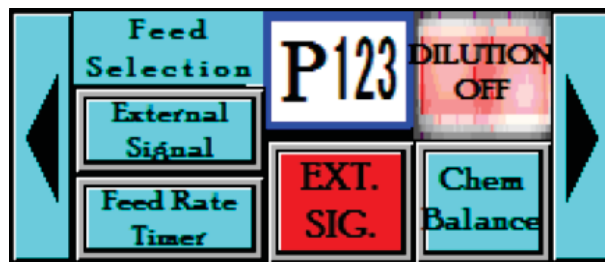

figure 7

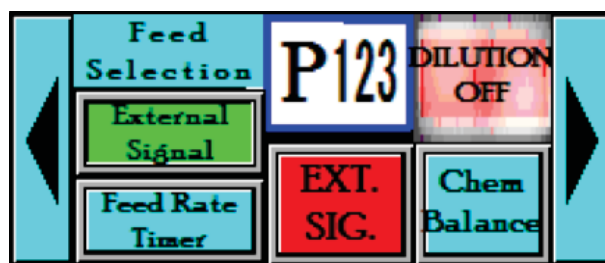

figure 8

Pulsar® 500 Startup Procedure: Control Panel

Power Up Programming Directions (cont'd)

12. Press the 'Right Arrow' button on the feed selection screen (figure 9), to enter the feeder model selection screen (figure 12). **A feeder model size and booster pump mode must be selected for the feeder to operate. (LOG IN to select.)**

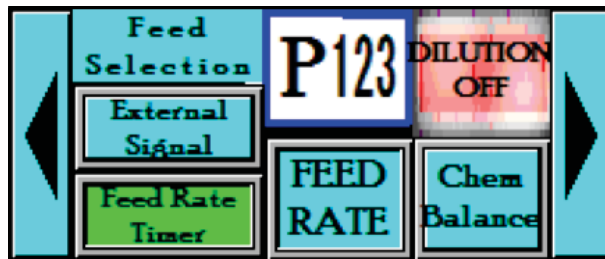

figure 9

- a. **Econo Mode** Runs the booster pump for 20 seconds after the last valve activation (whether feed or wash), then shuts off the Booster Pump to conserve energy. The minimum runtime is 5 minutes.
- b. **Always On** runs the Booster Pump continuously while the flow switch is on and when the alarm state is OK. Push the pump start button to toggle the booster pump ON/OFF. If the pump has not run for a minimum time of 5 minutes, the pump will not turn off when the button is pressed.
- c. **Remember that the E-STOP and FLOW SWITCH pre-empt any activation of the pump. If the E-STOP is activated (manually pressed) or the Flow switch doesn't sense flow, the pump will not turn on.**

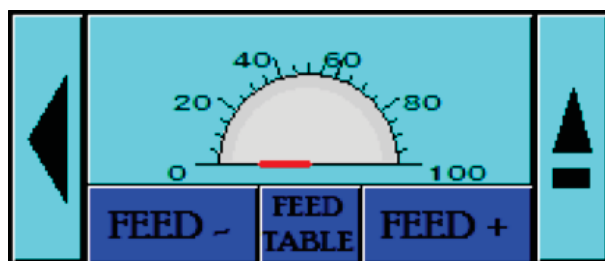

figure 10

13. Figure 13 (page 16) shows that a Pulsar® 140 Feeder has been selected and that the booster pump is in 'Econo Mode'. This will turn on the booster pump when chlorine feed is required and will turn off the pump 20 seconds after the wash cycle has ended when feed is no longer required. **Using econo mode requires the use of the check valve in the discharge tubing to the venturi.**

P140 FEED RATE			
FEED/LBS	FEED/LBS	FEED/LBS	FEED/LBS
5% = 8	30% = 49	55% = 90	80% = 130
10% = 16	35% = 57	60% = 98	85% = 139
15% = 24	40% = 65	65% = 106	90% = 147
20% = 33	45% = 73	70% = 114	95% = 155
25% = 41	50% = 82	75% = 122	100% = 163

figure 11

14. Figure 14 (page 16) shows that a Pulsar® 45 Feeder has been selected, and that the booster pump is in 'Always On' mode. When in 'Always On' mode, the 'PUMP START' button must be pressed only once, and will show 'PUMP ON' when running.

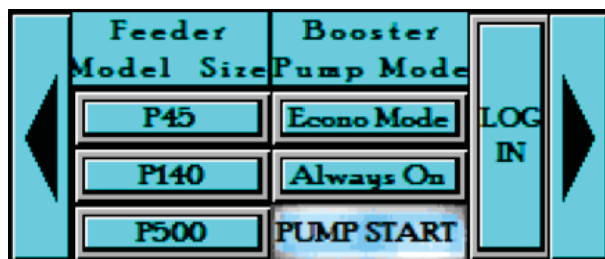

figure 12

Pulsar® 500 Startup Procedure: Control Panel

Power Up Programming Directions (cont'd)

15. **IMPORTANT!!** Once the feeder setup is complete, go back to the main screen and press the “Feed Start” button to start the feed process - This button is on a 2 second delay and must be touched for 2 seconds for it to toggle on or off. (figure 2, page 13)

16. The ALARM PAGE can be accessed by pressing the alarm button on the main control screen. The last active alarm will be shown. Each alarm can be highlighted by pressing the scroll up and scroll down buttons. Pressing the Last Alarm button will highlight the most recent alarm. Pressing ALARM HELP will open a pop up window with a troubleshooting guide for that particular alarm.

17. Figure 15 shows the alarm page, showing an alarm history of all alarms that are not acknowledged, as well as the time of occurrence, description, and recovery time. (When logged in as tech, press ‘ACK’ to clear a recovered alarm.)

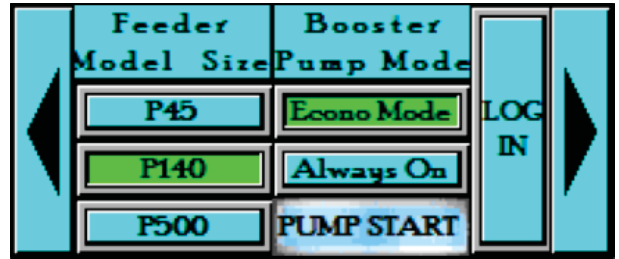

figure 13

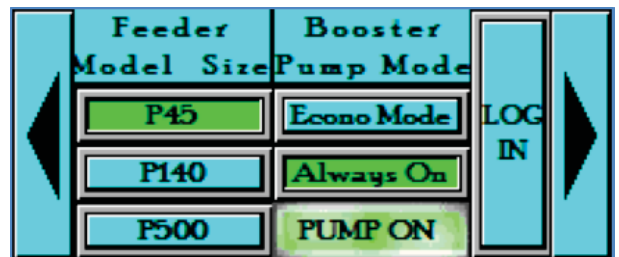

figure 14

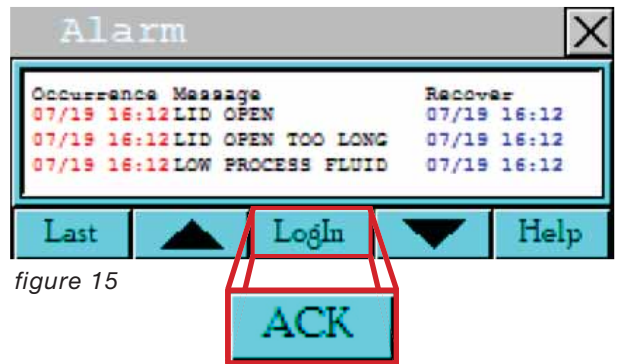

figure 15

Pulsar® 500 Preventative Maintenance

Calcium Hypochlorite by the nature of its manufacture contains a small amount of calcium carbonate. Proper water balance will minimize the buildup of calcium carbonate solids in the **Pulsar® 500 Feeder**; however, periodic cleaning of feeder components is normal and recommended. The following is a list of the parts to be cleaned and the proper procedures to do so.

A. Recommended Maintenance Frequency Based on Alkalinity

Parts to be Inspected and Cleaned	Alkalinity (ppm)	Frequency	Estimated Time
1. Hopper, Grid, and sensors			
2. Spray Nozzle and Wash/Agitator Nozzle			
3. Venturi		Monthly	
4. Manifold Assemblies			
5. Supply and Discharge Lines	80 max		2 hours
6. Booster Pump		Quarterly	
7. Solenoid Valves		2 Years	

Pulsar® 500 Preventative Maintenance

B. Preventative Maintenance Schedule

Preventative Maintenance: Daily (24 HRS)

Description / Maintenance

Item

Lid Sensor Shut-off (Part 3, pg 31): Inspect lid sensor operation by removing the lid and making sure the alarm light on the control panel screen is activated – deactivate by re-installing lid. If the alarm does not come on when the lid is removed, visually inspect the lid sensor making sure that no foreign material is on it. If the alarm does not reset when the lid is replaced, adjust the switch closer to the lid contactor by sliding up bracket. If no debris is on the sensor and adjustments don't appear to be working, notify maintenance to inspect/repair the lid sensor.



Note: The light on the lid switch will illuminate when connection is made with lid contactor.

Check Duration: About 1 minute

MON	TUES	WED	THUR	FRI	SAT	SUN

Hopper Basket/Grid (Parts 2 & 4, pg 31): Visually inspect hopper briquette level. Verify there is sufficient amount of briquettes to be fed until next scheduled visit. Make sure the grid of the hopper is completely covered with a depth of at least 3" to 4" of briquettes. If briquettes are moist around the outer circumference of the hopper, move the briquettes to the center of the hopper and add new briquettes around them.



Check Duration: Less than 2 minutes

MON	TUES	WED	THUR	FRI	SAT	SUN

Inlet Manifold Assembly (pg 34): Verify that there are no leaks at any of the fittings.



Check Duration: About 1 minute

MON	TUES	WED	THUR	FRI	SAT	SUN

continued

Pulsar® 500 Preventative Maintenance

B. Preventative Maintenance Schedule

Preventative Maintenance: Daily (24 HRS)

Description / Maintenance

Inlet Supply Solenoid Valves (Part 20, pg 34): Ensure that the solenoid valve coils are not hot to the touch. If coil is hot to the touch, make sure inlet ball valve (part 24, pg 34) is open during fill cycle allowing water to pass through the solenoid valves for water cooling. If ball valve is open then either replace or rebuild solenoid valve. The solenoid valve could buzz very slightly under normal conditions. If the solenoid starts making a rattling noise when energized, consider replacing or rebuilding the valve.

Check Duration: About 1 minute

Item



MON	TUES	WED	THUR	FRI	SAT	SUN

Preventative Maintenance: Weekly (7 DAYS)

Description / Maintenance

Inlet Manifold Line Strainer Assembly (Part 21, pg 34): Close the water supply valve (Part 24, pg 34) and remove strainer bowl from the inlet manifold and inspect for debris. Remove strainer screen and wash it out prior to replacing it back into the strainer bowl. If the screen appears damaged or has a hole in it, replace with a new screen. Visually inspect for cracks on the strainer and make sure there is no leak anywhere on the strainer's body. Re-install the strainer bowl back into the strainer body.

Check Duration: Around 10-15 minutes

Item

WEEK 1	WEEK 2	WEEK 3	WEEK 4	WEEK 5	WEEK 6	WEEK 7	WEEK 8

continued

Pulsar® 500 Preventative Maintenance

B. Preventative Maintenance Schedule

Preventative Maintenance: Monthly (30 DAYS)

Description / Maintenance

Item

Manifold Assemblies (Spray Manifold, Wash Manifold, pg 32): Verify that there are no leaks at any of the fittings. Make sure the inlet ball valve (part 24, pg 34) is open during operation.

Check Duration: Around 5 minutes



First Week of:

Jan	Feb	Mar	Apr	May	Jun	Jul	Aug	Sep	Oct	Nov	Dec

Hopper Basket / Grid (Parts 2 & 4, pg 31): Visually inspect the hopper grid for any plugging. If plugging or build up is observed at 50% or greater on the grid, then clean existing hopper/grid or replace with a previously cleaned hopper/grid. While inspecting the basket also look for any visible cracks. If any cracks are found, replace the grid as soon as possible before starting the feeder back up.

Please follow “Cleaning Procedure” (pgs 24-28) to clean the hopper and grid if required.

Note: To increase the period between Grid cleanings, allow Briquette Hopper to completely empty once a week.

Check Duration: About 5 minutes



First Week of:

Jan	Feb	Mar	Apr	May	Jun	Jul	Aug	Sep	Oct	Nov	Dec

continued

Pulsar® 500 Preventative Maintenance

B. Preventative Maintenance Schedule

Preventative Maintenance: Monthly (30 DAYS)

Description / Maintenance	Item
<p>Venturi (Part 33, pg 35): Inspect venturi and verify that it is not clogged with scale build up. This will require that the tubing and tubing fittings be removed from the suction side of the venturi. If there is any scale build-up, perform cleaning procedure on pg 27.</p> <p>Visually look at lines and fittings on the inlet, outlet, and suction sides of the venturi for leaks. If needed, re-tighten the fittings or replace them.</p> <p>Check Duration: 10 minutes</p>	

First Week of:

Jan	Feb	Mar	Apr	May	Jun	Jul	Aug	Sep	Oct	Nov	Dec
-----	-----	-----	-----	-----	-----	-----	-----	-----	-----	-----	-----

<p>Feeder Discharge Tank / Molded Base with Inserts (Part 1, pg 31): Visually inspect the solution reservoir and ensure that there is no calcium buildup on the discharge valve (DV) float, DV arm, and DV body (parts 8, 9, and 10, pg 33). Calcium buildup on the DV can dramatically interfere with feeder discharge operation that can lead engaging the overflow switch or possible overflowing of the feeder.</p> <p>If any build up is found please follow “Cleaning Procedure” (pgs 24-28)</p> <p>Check Duration: 5 minutes</p>	
---	---

First Week of:

Jan	Feb	Mar	Apr	May	Jun	Jul	Aug	Sep	Oct	Nov	Dec
-----	-----	-----	-----	-----	-----	-----	-----	-----	-----	-----	-----

continued

Pulsar® 500 Preventative Maintenance

B. Preventative Maintenance Schedule

Preventative Maintenance: Monthly (30 DAYS)

Description / Maintenance

Item

Safety Overflow Switch (Part 37, pg 31): Visually inspect the Safety Overflow Switch when the solution tank is empty to ensure no calcium deposits are forming around the sensor and that the sensor is not corroding. If degradation is observed, replace switch. Make sure switch is positioned as shown in the figure at right.

Check Duration: 2 minutes



First Week of:

Jan	Feb	Mar	Apr	May	Jun	Jul	Aug	Sep	Oct	Nov	Dec

Spray Nozzles (Part 28, pg 32): Remove hopper basket and visually inspect spray nozzles for fouling. Remove spray tree and ensure no foreign material is stuck inside the spray nozzles. If foreign material is found, clean the spray tree by soaking in Pulsar® Plus Acid Cleaner 50 and follow the Chemical Hopper cleaning procedure (pgs 24-25). Do not mechanically clean nozzles. This could lead to damaging the nozzles. Replace any spray nozzle that is physically damaged, or not spraying in a uniform full-cone pattern. After installing the spray tree, make sure that the spray tree and nozzles are level – this is achieved by applying a level to the spray tree and nozzles.

Check Duration: Less than 10 minutes



First Week of:

Jan	Feb	Mar	Apr	May	Jun	Jul	Aug	Sep	Oct	Nov	Dec

Washdown and Well Agitator Nozzles (Parts 30 and 31, pg 32): Remove hopper basket and visually inspect wash down nozzles for fouling. The well agitator nozzle can become blocked over time. Remove the washdown and well agitator nozzles and clean nozzle orifice if needed by soaking in a Pulsar® Plus Acid Cleaner 50 solution.

Check Duration: Around 10 minutes



First Week of:

Jan	Feb	Mar	Apr	May	Jun	Jul	Aug	Sep	Oct	Nov	Dec

Pulsar® 500 Preventative Maintenance

B. Preventative Maintenance Schedule

Preventative Maintenance: Quarterly (90 DAYS)

Description / Maintenance

Booster Pump: Visually check for leaks on and around the pump, including the suction and discharge piping and fittings.

Check Duration: About 1 minute

Item



First Week of:

Jan (once during Jan-Mar)	Apr (once during Apr-Jun)	Jul (once during Jul-Sep)	Oct (once during Oct-Dec)
---------------------------	---------------------------	---------------------------	---------------------------

Preventative Maintenance: Biennial (2 YEARS)

Description / Maintenance

Inlet Supply Solenoid Valves (Part 20, pg 34): Replace solenoid valve every two years to ensure proper system operation.

Check Duration: No more than 30 minutes

Item



First Week of:

Jan (once every 2 years)	Jan (once every 2 years)
--------------------------	--------------------------

Pulsar® 500 Cleaning Procedure

Personal Protective Equipment and Parts Needed for Cleaning

Safety



Rubber Gloves



Safety Glasses



Apron

Tools





Putty Knife

Supplies

- Clean 5 gallon plastic bucket
- Drain line from base of feeder (routed to the drain)
- Hose

Caution: Don PPE prior to performing any work on the Pulsar® System and handling the Pulsar® Plus Acid Cleaner 50

Cleaning Solution

Tool	Step	Instruction
		Use Pulsar® Plus Acid Cleaner 50
		Warning: DO NOT use Muriatic Acid to perform the following procedures. Chlorine gas may evolve causing serious injury or possible death.
		

Chemical Hopper Cleaning

Tool	Step	Instruction
	1.1	To the maximum extent practicable, allow feeder to use up the briquettes in the hopper prior to cleaning.
	1.2	Shut the venturi isolation ball valve (Part 24, pg 35) on the Discharge Assembly from the feeder to the venturi.
	1.3	Shut the inlet isolation ball valve (Part 24, pg 34) on the Inlet Manifold Assembly from the outlet of the booster pump to the feeder.
	1.4	Remove the Briquette hopper lid (Part 3, pg 31) and then remove the Briquette hopper (Part 2, pg 31) off of the Base Assembly (Part 1, pg 31) and place on a clean surface.
		

continued





Pulsar® 500 Cleaning Procedure

Chemical Hopper Cleaning

Tool	Step	Instruction
	1.5	Remove any remaining unused Pulsar® Plus Briquettes and place into a clean dry bucket, and then remove the Briquette Grid (Part 4, pg 31). Unused Briquettes, including wetted briquettes may be reused once cleaning is complete. Dispose of used “mushy” Briquettes properly. Dissolve “mushy” Briquettes in clean 5 gallon pail of water to make chlorine solution. Add chlorine solution to skimmer or gutter.
	1.6	Clean off as much solid material from the grid and hopper as possible.
	1.7	Place the briquette grid and hopper in a shallow tub. Fill with 2 gallons [7.57 liters] of water. Slowly pour 1 quart [.95 liters] Pulsar® Plus Acid Cleaner 50 into the tub.
	1.8	Frequent agitation may be required to dissolve residue and scale. Allow acid to dissolve residue and scale, evident by the foaming action.
	1.9	After 1 hour, check for the presence of scale on the grid. If necessary, add additional Pulsar® Plus Acid Cleaner 50 to dissolve any remaining scale or scrape with putty knife. Rinse the Briquette grid thoroughly with fresh water.
	1.10	Repeat steps 1.8 through 1.10 to clean the spray tree, and wash manifold assembly.
	1.11	Visually verify the spray nozzles are clean prior to re-assembling.
	1.12	Once clean, replace Valve Plate Assembly and Briquette Hopper back on top of the Base Assembly then place the Briquette grid back into the bottom of the hopper.
	1.13	Open the venturi isolation ball valve (Part 24, pg 35) on the discharge line from the feeder to the venturi.
	1.14	Open the inlet isolation ball valve (Part 24, pg 34) on the Inlet Manifold Assembly from the outlet of the booster pump to the feeder.

Pulsar® 500 Cleaning Procedure

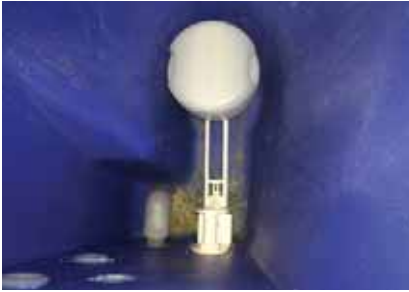
Tank Cleaning

Tool	Step	Instruction	
	2.1	To the maximum extent practicable, allow feeder to use up the briquettes in the hopper prior to cleaning.	
	2.2	Shut the venturi isolation ball valve (Part 24, pg 35) on the discharge line from the feeder to the venturi.	
	2.3	Shut the inlet isolation ball valve (Part 24, pg 34) on the Inlet Manifold Assembly from the outlet of the booster pump to the feeder.	
	2.4	Remove the hopper and lid from the Base Assembly and place on a clean surface. Follow “Chemical Hopper Cleaning” instructions (steps 1.1 – 1.14) above if hopper requires cleaning.	
	2.5	Remove the entire Valve Plate including the spray manifolds and solenoids and place in bucket or tray.	
	2.6	The discharge valve (DV) (Part 10, pg 33), DV arm (Part 9, pg 33), and DV float (Part 8, pg 33) can be cleaned in place with acid.	
	2.7	Rinse the DV parts with fresh water and examine them carefully to remove any excess scaling formed on the parts.	
	2.8	Remove the 3/4" [19 mm] plug from the drain port (pg 8) and route it to a drain. Caution: Place a pan below the drain during removal of the drain plug. Some chlorine solution may be released. Flush out the Base Assembly through the drain port. Allow the feeder to completely drain then close the drain port.	

continued

Pulsar® 500 Cleaning Procedure

Tank Cleaning

Tool	Step	Instruction
	2.9	Fill the Base Assembly 1" [2.54mm] below the overflow port (pg 7) and add 1 quart [0.95 liters] Pulsar® Plus Acid Cleaner 50.
	2.10	Frequent agitation may be required to dissolve residue and scale. Allow acid to dissolve residue and scale, evident by the foaming action.
	2.11	After 1 hour, check for the presence of scale in the tank and on the DV parts. If necessary, add additional Pulsar® Plus Acid Cleaner 50 to dissolve any remaining scale or scrape with putty knife.
	2.12	Open the venturi isolation ball valve (Part 24, pg 35) on the discharge line from the feeder to the venturi. Allow the venturi to suck the remaining solution from the Base. The solution from the Base Assembly will clean the discharge valve, outlet tubing and venturi.
	2.13	Replace hopper and lid back onto the Base Assembly. Replace the Valve Plate Assembly along with the connected Spray Manifold Assembly (pg 32) to the Base Assembly.
	2.14	Open the inlet isolation ball valve (Part 24, pg 34) on the Inlet Manifold Assembly from the outlet of the booster pump to the feeder.

Venturi Cleaning

Tool	Step	Instruction
	3.1	Shut the inlet valve (part 24, pg 34) to the feeder.
	3.2	Get a gallon jug and fill half of it with water
	3.3	Add 1/2 quart of Pulsar® Plus Acid Cleaner 50 to the water in the jug.
	3.4	Shut the outlet valve (part 24, pg 35) to the Venturi.
	3.5	Disconnect the tubing from the check valve.
	3.6	Place end of tubing in the jug with the water/acid cleaning solution.
	3.7	Open outlet valve and suck out 1/2 of the contents then shut the valve.
	3.8	Let the solution sit for 15 minutes.
	3.9	Open the outlet valve and draw out remainder of the solution from the jug.
	3.10	Shut the outlet valve and reconnect tubing to the check valve outlet.
	3.11	Open the outlet valve to the venturi.
	3.12	Open the inlet valve to the feeder.

Pulsar® 500 Cleaning Procedure

Check Valve Cleaning

Tool	Step	Instruction	
	4.1	Shut the inlet valve to the feeder and outlet valve to the venturi (part 24, pg 34 & 35).	
	4.2	Get a gallon jug and fill half of it with water	
	4.3	Add 1/2 quart of Pulsar® Plus Acid Cleaner 50 to the water in the jug.	
	4.4	Disconnect the check valve (part 6, pg 33) from the tubing.	
	4.5	Disassemble the check valve in accordance with the picture making sure not to lose any of the components.	
	4.6	Place check valve parts in the Pulsar® Plus Acid Cleaner 50 for 15 minutes to remove scale build up.	
	4.7	Reassemble check valve verifying proper placement of components back into the assembly.	
	4.8	Reconnect check valve into tubing and open inlet and outlet valves.	

check valve scale buildup examples

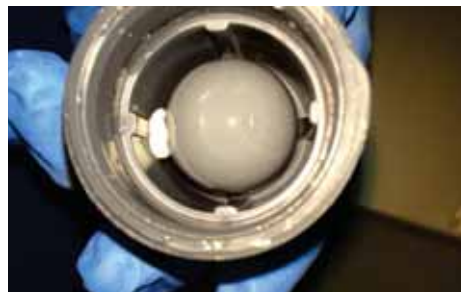

Pulsar® 500 Troubleshooter's Guide

Problem	Cause	Solution
Insufficient water flow to feeder	Check water flow through spray nozzles	Clean spray nozzles with compressed air
	Safety Overflow Switch in closed position	If SO Switch is stuck, lower gently to reset switch
	Inlet Valve closed	Open Inlet Valve
	Inlet Filter plugged	Clean Inlet Filter
Insufficient chlorine in pool	Solenoid Valve not operating properly	Check with Dealer
	Feed rate/output too low	Increase feed rate/output on timer or ORP unit
	Feeder empty	Refill Briquette Tank with Pulsar® Plus Briquettes
	No/low inlet water flow	See insufficient water flow section
	Outlet Shutoff Valve closed	Open Outlet Shutoff Valve
	Clogged Discharge Tubing	Replace discharge tubing
	Clogged Briquette Tank Grid	Refer to Section A
Excess chlorine in pool	Clogged Venturi System	Remove and soak in dilute Pulsar® Plus Acid Clear 50 or E-Stop engaged on Control Panel
	Automatic Controller problem	Refer to Automatic Controller manual
	Feed rate/output too high	Decrease feed rate/output on timer
	Discharge Tubing not properly installed in fittings	Reinstall Discharge Tubing
Air leaks	Discharge Valve seat failure	Replace Discharge Valve Arm
	Scale prevents Discharge Valve from properly seating	Remove Discharge Valve Assembly and soak in dilute Pulsar® Plus Acid Cleaner 50 to remove scale
	Pinched O-rings in Tubing Connectors	Inspect O-rings on discharge side of feeder
Feeder overflow	Discharge Tubing clogged	Refer to Section A or Replace Discharge Tubing
	Insufficient outlet suction	Check with Dealer
Feeder not feeding	Emergency overflow switch failure	Check with Dealer
	Isolation Ball Valve shut on either Inlet Manifold or venturi discharge	Open Ball Valves
	Feed hasn't been started	Push Feed Start button for 2 seconds

Pulsar® 500 Feeder: Detailed View

See pgs 36-37 for Diagram Descriptions

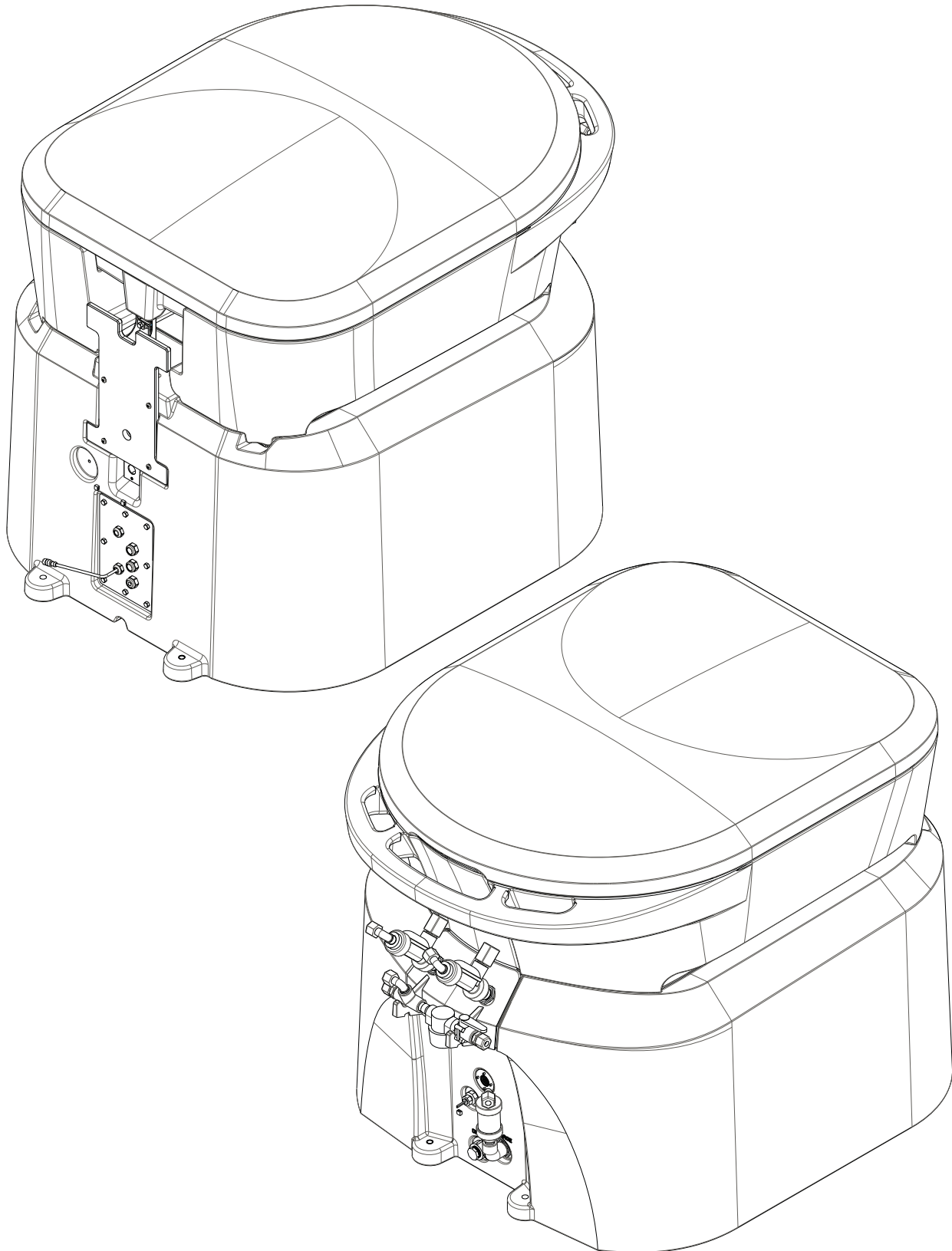

Pulsar® 500 Feeder: Detailed View

See pgs 36-37 for Diagram Descriptions

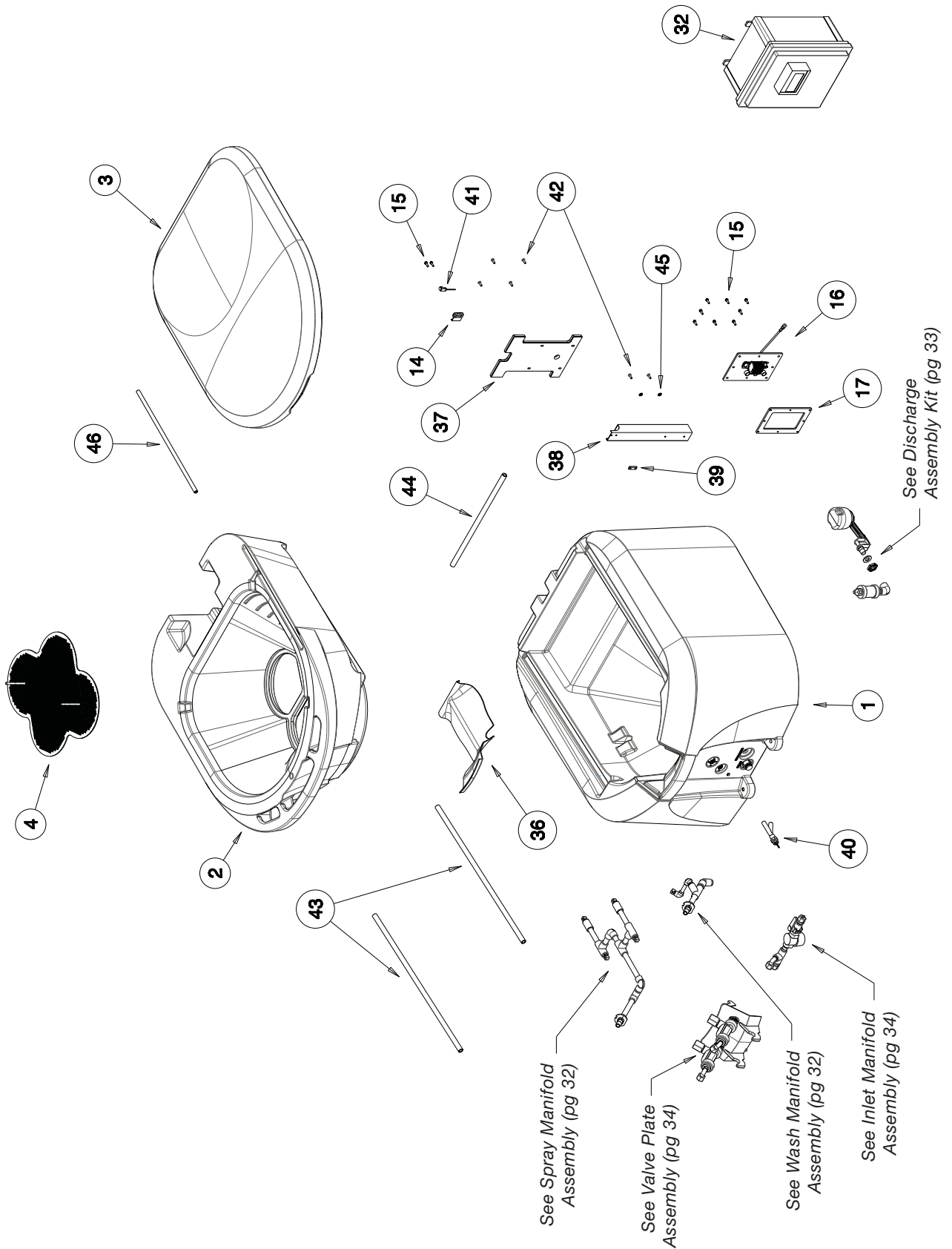

Pulsar® 500 Feeder: Assembly Views

See pgs 36-37 for Diagram Descriptions

Spray Manifold Assembly

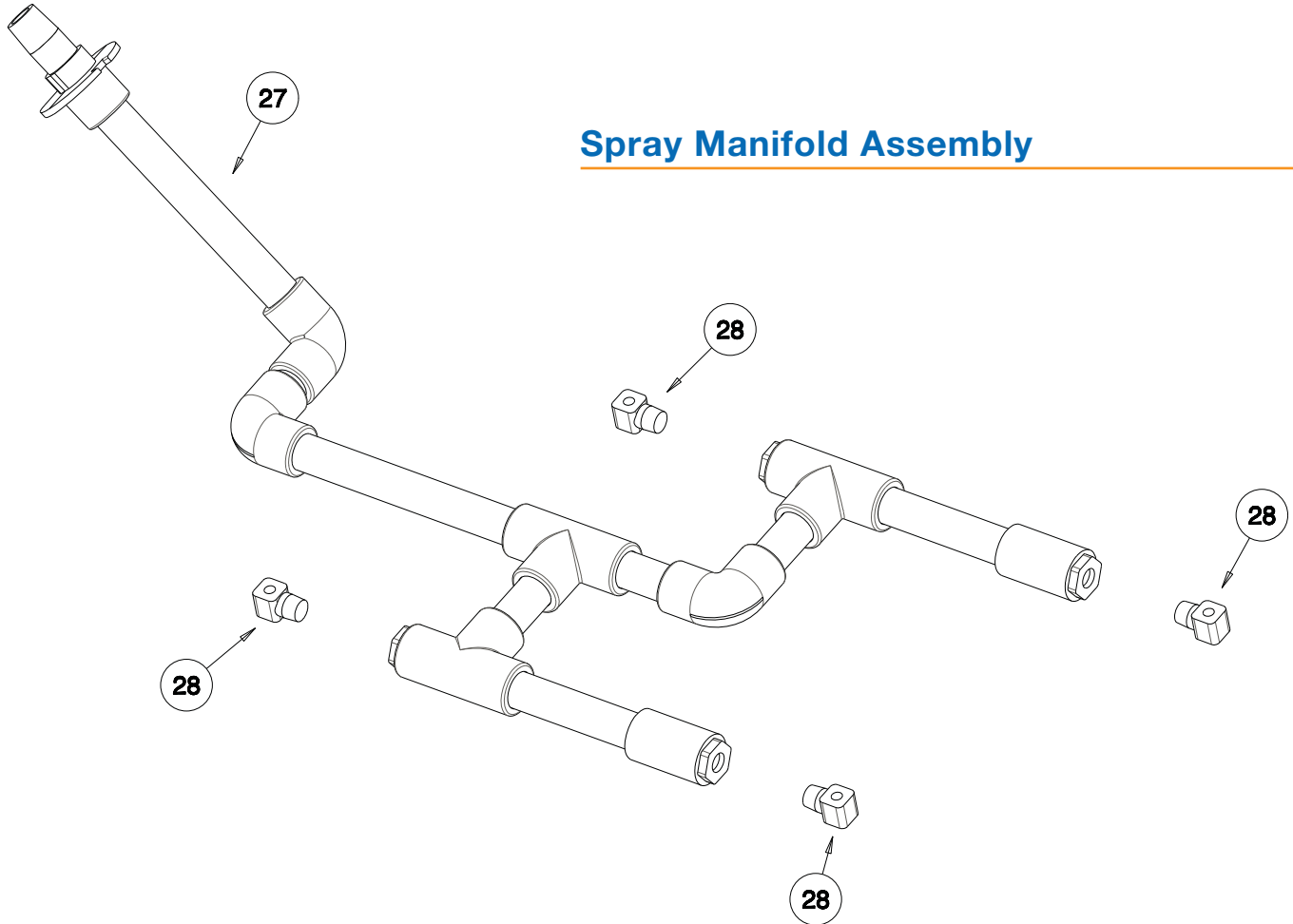

Wash Manifold Assembly

See Appendix A for Modifications

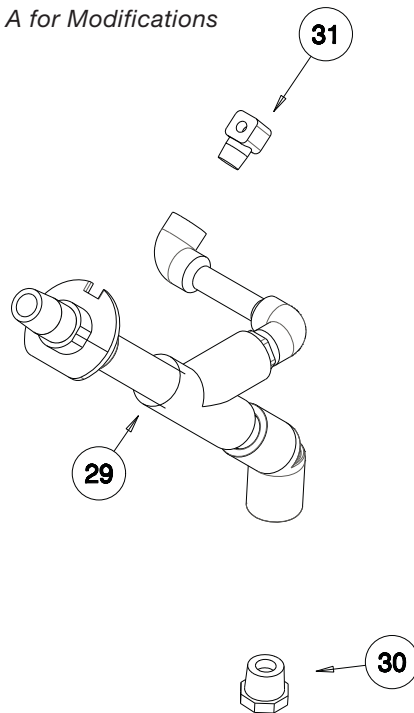

Pulsar® 500 Feeder: Assembly Views

See pgs 36-37 for Diagram Descriptions

Discharge Assembly Kit

See Appendix B for Check Valve Orientation Info

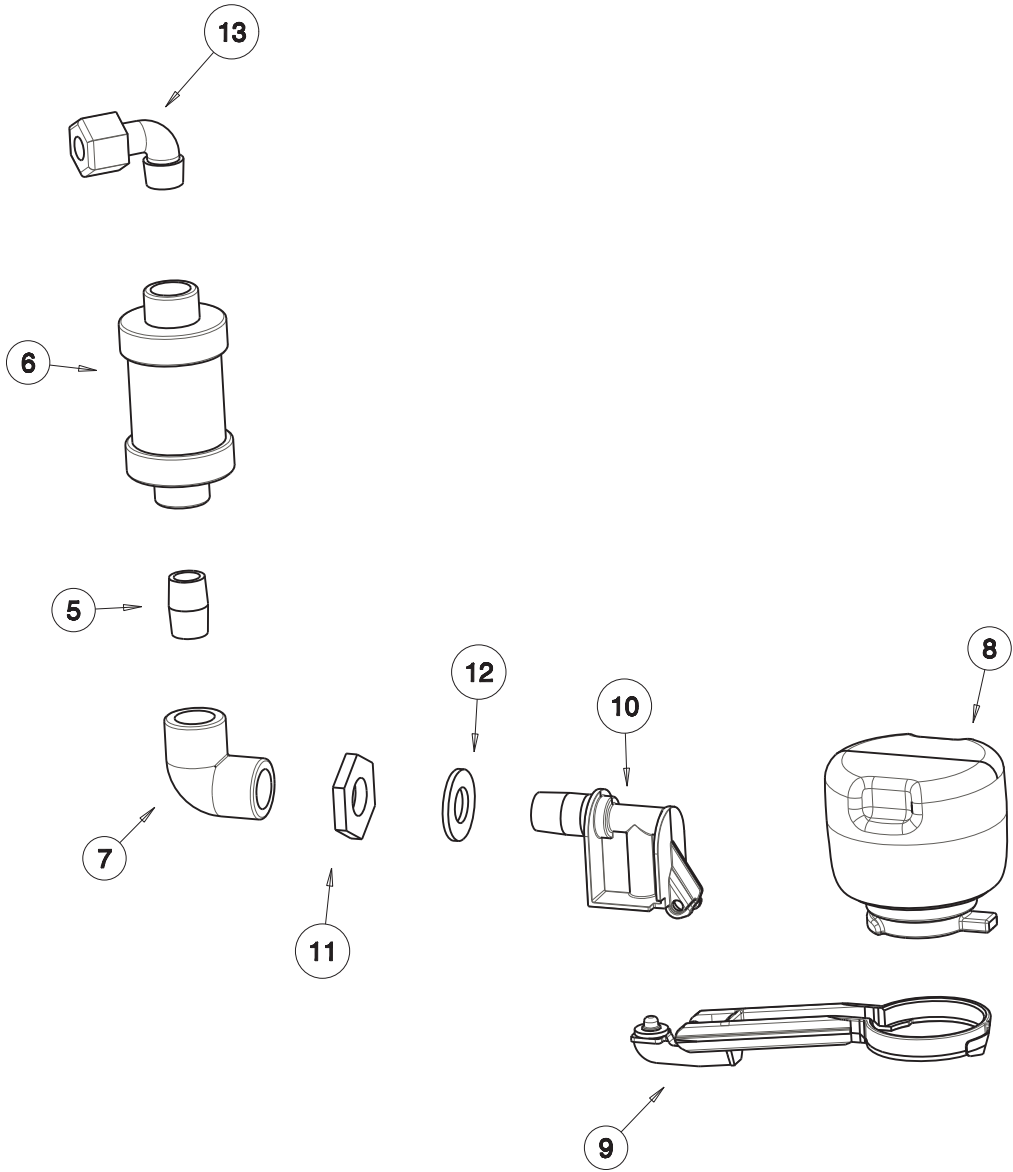

Pulsar® 500 Feeder: Assembly Views

See pgs 36-37 for Diagram Descriptions

Inlet Manifold Assembly

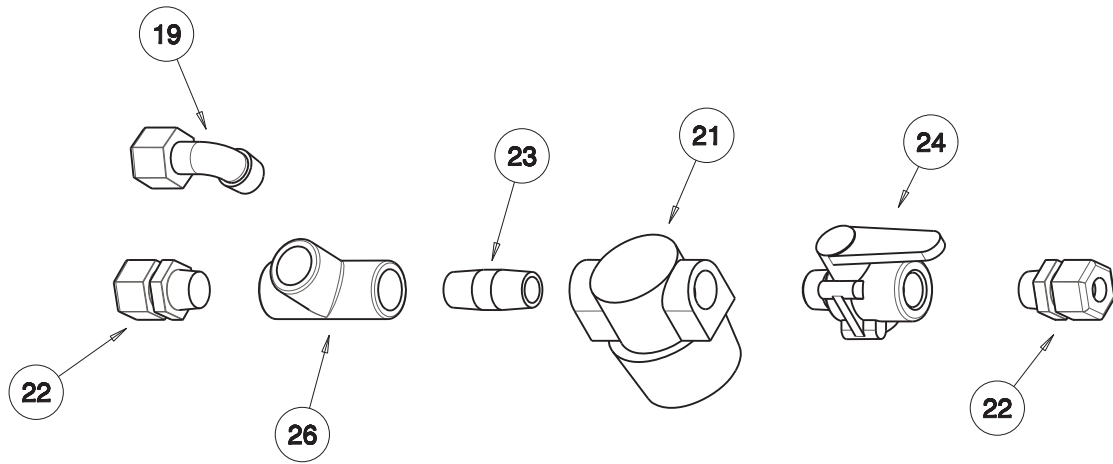

Valve Plate Assembly

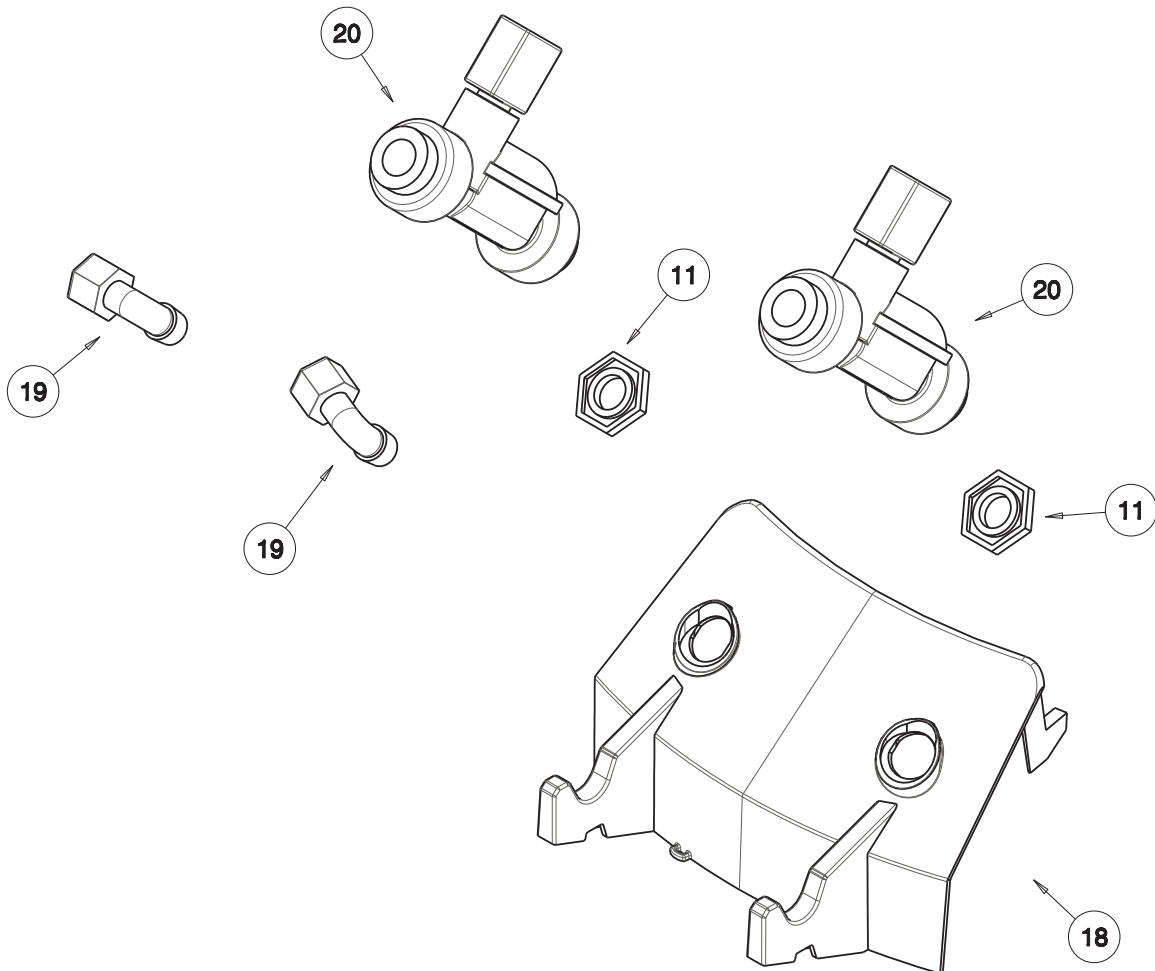

Pulsar® 500 Feeder: Assembly Views

See pgs 36-37 for Diagram Descriptions

Pulsar® Installation Kit

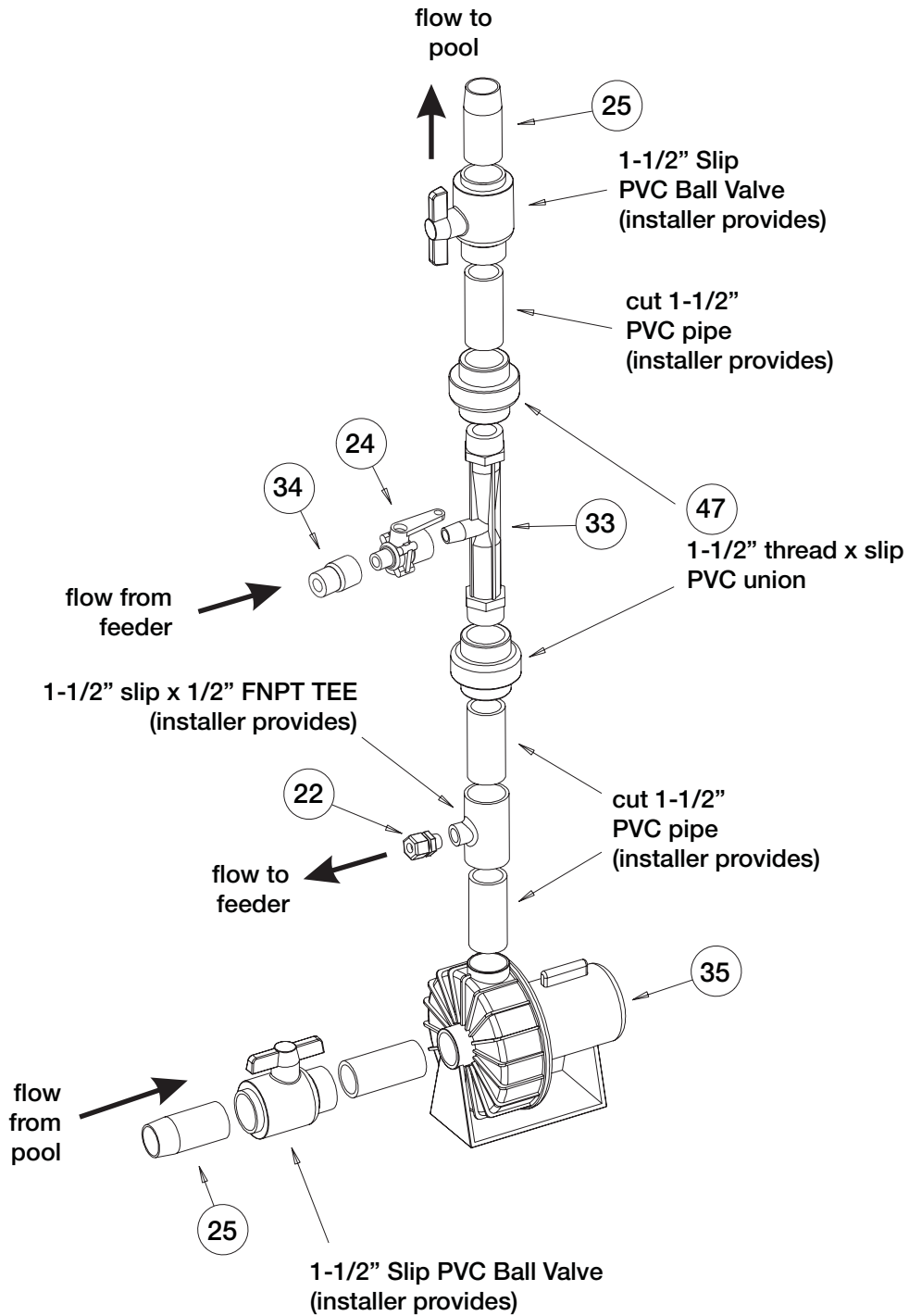

Pulsar® 500 Feeder: Diagram Descriptions

Diagram Number	Location	Part Number	Qty/ Unit	Description
1	BASE ASSEMBLY	79641	1	BASE WITH INSERTS
2	HOPPER ASSEMBLY	79645	1	HOPPER
3	LID ASSEMBLY	79659	1	LID
4	HOPPER ASSEMBLY	79643	2	GRID
5	DISCHARGE ASSEMBLY KIT	71916	1	1/2" X 1-1/2" NIPPLE
6	DISCHARGE ASSEMBLY KIT	79218	1	CHECK VALVE
7	DISCHARGE ASSEMBLY KIT	79222	1	1/2" PVC ELBOW
8	DISCHARGE ASSEMBLY KIT	79810	1	DV Float
9	DISCHARGE ASSEMBLY KIT	79805	1	DV Arm
10	DISCHARGE ASSEMBLY KIT	79806	1	DV BODY
11	DISCHARGE ASSEMBLY KIT	71583	1	DV NUT
11	VALVE PLATE ASSEMBLY	71583	2	DV NUT
12	DISCHARGE ASSEMBLY KIT	71576	1	DV GASKET
13	DISCHARGE ASSEMBLY KIT	71898	1	W8ME8
14	BASE ADD ON'S (Features)	79647	1	BRACKET LID SWITCH
15	BASE ADD ON'S (Features)	76360	12	ISOPLAST BOLT 1/4 - 20 X 3/4"
16	BASE ADD ON'S (Features)	79616	1	J-BOX ASSEMBLY WITH TURCK CABLE
17	BASE ADD ON'S (Features)	79618	1	J-BOX GASKET
18	VALVE PLATE ASSEMBLY	79625	1	VALVE PLATE
19	VALVE PLATE ASSEMBLY	71898	2	W8ME8
19	INLET MANIFOLD ASSEMBLY	71898	1	W8ME8
20	VALVE PLATE ASSEMBLY	79664	2	SOLENOID (ASCO 8212A519S0100F1)
21	INLET MANIFOLD ASSEMBLY	79812	1	LINE STRAINER ASSEMBLY
22	INLET MANIFOLD ASSEMBLY	71890	2	W8MC8
22	INSTALLATION KIT	71890	1	W8MC8
23	INLET MANIFOLD ASSEMBLY	76255	1	PVC THREADED NIPPLE - 1/2" NPT X 2"
24	INLET MANIFOLD ASSEMBLY	71627	1	MF BALL VALVE
24	INSTALLATION KIT	71627	1	MF BALL VALVE
25	INSTALLATION KIT	71548	1	1-1/2" x 12" PVC THREADED NIPPLE
26	INLET MANIFOLD ASSEMBLY	71912	1	1/2" NPT TEE
27	SPRAY MANIFOLD ASSEMBLY	79644	1	SPRAY MANIFOLD
28	SPRAY MANIFOLD ASSEMBLY	71888	4	422.566.5E.BC NOZZLE
29	WASH MANIFOLD ASSEMBLY	79650	1	WASH MANIFOLD
30	WASH MANIFOLD ASSEMBLY	79660	1	AGITATION NOZZLE 1 PER
31	WASH MANIFOLD ASSEMBLY	71888	1	WASH-DOWN NOZZLE

Pulsar® 500 Feeder: Diagram Descriptions

Diagram Number	Location	Part Number	Qty/ Unit	Description
32	CONTROL PANEL	79816	1	CONTROL PANEL WITH IDEC FT1A TOUCH
33	INSTALLATION KIT	71811	1	VENTURI (MAZZEI 1585X)
34	INSTALLATION KIT	71588	1	P8FC8
35	INSTALLATION KIT	79214	1	BOOSTER PUMP
36	BASE ASSEMBLY	79656	1	SHIELD 79656
37	BASE ADD ON'S (Features)	79610	1	ANTI TIP PLATE
38	BASE ADD ON'S (Features)	79642	1	MAST LID SWITCH
39	BASE ADD ON'S (Features)	79658	1	NUT PLATE
40	BASE ADD ON'S (Features)	79840	1	SAFETY OVERFLOW SWITCH (INCLUDED WITH 79616)
41	BASE ADD ON'S (Features)	79688	1	LID SAFETY SWITCH (INCLUDED WITH 79616)
42	BASE ADD ON'S (Features)	HD/Local	6	1/4 – 20 X 3/4" SS SCREW (2 MAST, 4 PLATE)
43	BASE ADD ON'S (Features)	HD/Local	2	HOPPER SKIDS (1/2" SCH 80 PVC PIPE; 32" LONG)
44	BASE ADD ON'S (Features)	HD/Local	1	SHIELD SUPPORT (1/2" SCH 80 PVC PIPE; 22" LONG)
45	BASE ADD ON'S (Features)	HD/Local	2	1/4" SS WASHER
46	HOPPER ASSEMBLY	HD/Local	1	PROP ROD (3/8" SCH 80 PVC PIPE; 24-1/2" LONG)
47	INSTALLATION KIT	71907	2	1-1/2" SLIP x 1-1/2" FNPT PVC UNION

NOT SHOWN IN DIAGRAMS

N/A	CONTROL PANEL	79669	1	FLOW SWITCH
N/A	INSTALLATION KIT	71626	1	20' 1/2" OD LDPE TUBING
N/A	BASE DRAIN ASSEMBLY	HD/Local	1	3/4" PVC HEX PLUG
N/A	BASE DRAIN ASSEMBLY	79621	1	INLET DRAIN SIPHON ASSEM
N/A	VALVE PLATE ASSEMBLY	HD/Local	1	1/2" OD LDPE TUBING 24" LONG
N/A	VALVE PLATE ASSEMBLY	HD/Local	1	1/2" OD LDPE TUBING 18" LONG
N/A	MISCELLANEOUS	HD/Local	2	LEAD SHIELD (FOR 5/16" LAG BOLT)
N/A	MISCELLANEOUS	HD/Local	2	GALVANIZED LAG BOLT WASHER (5/16")
N/A	MISCELLANEOUS	HD/Local	2	5/16" X 3" GALVANIZED LAG BOLT
N/A	MISCELLANEOUS		1	MANUALS
N/A	MISCELLANEOUS		1	WARRANTY CARD

Appendices

Pulsar® Technical Bulletins

Appendix A – Pulsar® New Wash Agitation Nozzles	39 - 42
Appendix B – Check Valve Orientation.	43
Appendix C – Pulsar CRS™ System Upgrades	44 - 47
Appendix D – Pulsar® Cable Length Guide to Control Panel.	48
Appendix E – ORP Leakage Current Tech Bulletin	49 - 50

Pulsar® Upgrades Part Numbers

Part Description	New Part Numbers	Existing Part Numbers
Agitation Nozzle	73057	—
PS-45 Washdown Nozzle Assembly	73058	—
PS-140 Washdown Nozzle Assembly	73059	—
Wash Nozzle	73060	—
Handle-less Grid PS-45*	—	79651
Handle-less Grid PS-140*	—	79652
Handle-less Grid PS-500*	—	79643

*Existing part is modified and is ordered using the current part number

Appendix A – Pulsar® New Wash Agitation Nozzles

Pulsar® Upgrades Part Numbers

Part Description	New Part Numbers	Existing Part Numbers
Agitation Nozzle Assembly	73057	—
PS-45 Washdown Manifold	73058	—
PS-140 Washdown Manifold	73059	—
Wash Nozzle (120° full cone)	73060	—
PS-45 Washdown kit (manifold & nozzle)	73062	—
PS-140 Washdown kit (manifold & nozzle)	73063	—
Handle-less Grid PS-45*	—	79651
Handle-less Grid PS-140*	—	79652
Handle-less Grid PS-500*	—	79643

*Existing part is modified and is ordered using the current part number

Pulsar® Feeder Upgrades

Background

During the 2016 **Pulsar®** Dealer Meeting, a concern was expressed that some of the new feeders require substantial cleaning and maintenance. In addition, some dealers indicated that they observed drastic drops in chlorine residue after only a few weeks of use, possibly as a consequence of frequent clogging of the rapid grid, nozzle, discharge line and venturi, all of which can be caused by briquette “mushing”.

With focused analysis and testing of feeders in the field, the **Pulsar®** engineering team identified a few key operational features to be adjusted to address these issues. The washdown nozzles, agitation nozzles and grids on all three feeders are among some of the components that have been modified to improve performance and to reduce maintenance and cleaning frequency.

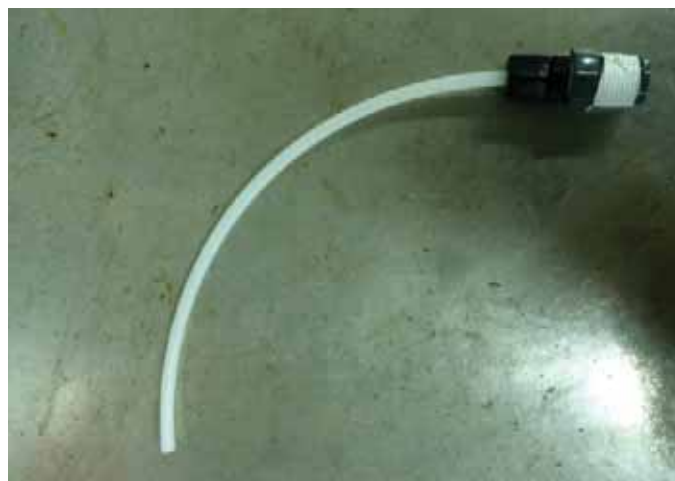

figure 1

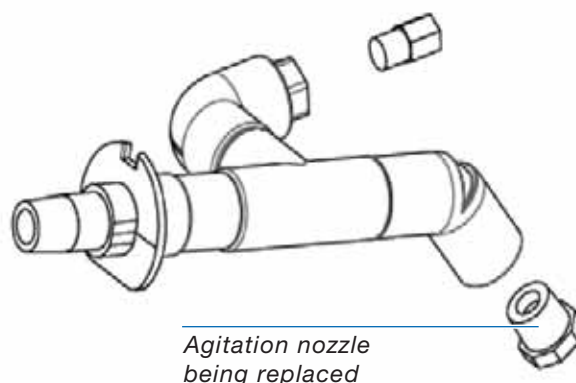

figure 2

Appendix A – Pulsar® New Wash Agitation Nozzles

New Agitation Nozzle

The agitation nozzle of the **Pulsar®** feeders is applicable to all three feeder sizes (PS-45, PS-140, and PS-500). The agitation nozzle is meant to spray a focused stream of water during every wash cycle to the bottom of the discharge tank in order to “agitate” the solution and not allow any heavy solids and scale to build up and form big clumps that can eventually clog the discharge valve inlet or downstream components such as the check valve or venturi.

Recent field testing has shown that directing the flow of water right to the bottom of the discharge tank using 1/8” ID tubing provides much better direct agitation of solids and helps reduce the level of scale formation. The updated agitation nozzle will be located in the same position as the previous version, but instead consist of an 11” long poly tubing (1/4”OD x 1/8” ID) (*figure 1, page 39*).

New Agitation Nozzle Installation

Prior to installation, straighten the tubing as best as possible so that it is pointed straight down when installed. The nozzle is a direct replacement of the old agitation nozzle. After screwing into the 45° elbow, verify that the tubing is directed so that it sits right next to the discharge valve (DV) (*figure 3*). This optimizes its performance and increases the chances that big clumps of scale will break down prior to getting pulled into the DV by the venturi vacuum.

PS-45, PS-140 Washdown Nozzle Upgrades

A new washdown nozzle was developed to help reduce premature briquette mashing. The washdown nozzle aims the flow directly downwards onto the feed nozzles and spray shield.

The new nozzle also has a 120° full cone spray which provides better overall coverage of the feed nozzle and spray shield area. The nozzle is also assembled with 1/2” schedule 40 pipe in lieu of 1/4” piping that the old washdown nozzle had (*see figures 4 & 5*). The bigger piping allows more water flow to the nozzle providing more pressure upon discharge increasing flow impingement. This improves the scale growth mitigation action on the feed nozzles and spray shield.



figure 3



figure 4



figure 5

Appendix A – Pulsar® New Wash Agitation Nozzles

Installation Steps for the PS-45 Washdown Nozzle

Prior to placing the valve plate assembly onto the base, remove the elbow (*figure 6*) from the 1/2" nipple and replace it with the new washdown assembly.

Disassemble the DV nut and washdown solenoid from the valve plate if more room is required to screw on the new washdown nozzle on onto the 1/2" nipple (*figure 7*).

Rotate and angle the nozzle slightly (approximately 15° - 20°) as necessary to provide maximum coverage to the entire spray shield and feed nozzle (*figure 8*). Activate the wash nozzle while adjusting to verify coverage.

Installation Steps for the PS-140 Washdown Nozzle

Disassemble the DV nut and washdown solenoid from the valve plate (*figure 9*). Prior to placing the valve plate assembly onto the base, remove the 1/2" to 1/4" bushing (*figure 10*) from the tee and replace it with the new washdown assembly by screwing the 1/2" nipple into the tee.

Orientation steps for the PS-140 washdown nozzle are similar to the PS-45 installation. The main objective is to make sure the flow coming from the nozzle covers all three feed nozzles. Angle the stem slightly upwards in order to provide maximum coverage to all three nozzles (*figures 11 & 12*). Activate the wash nozzle while adjusting the angle in order to physically verify complete coverage with your hands.



figure 7



figure 8



figure 9

Appendix A – Pulsar® New Wash Agitation Nozzles



figure 10

Handle-less Grids

During close monitoring of PS-140 feeders identified as having excessive cleaning requirements, a potential correlation was observed between clogged nozzles and scaling collecting on the handle nuts of the grid (figure 13). Removing the handles from the grid completely reduced the rate of clogging of the nozzles during subsequent feeder operation.

Excess scaling appears below handle nut; may be dropping bigger scale deposits on feed nozzles



figure 11



figure 13

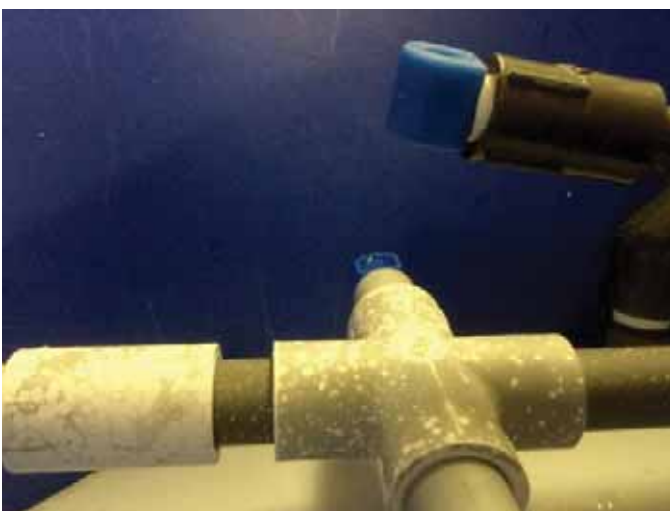

figure 12



figure 14 PS-140 Handle-less Grid

Appendix B – Check Valve Orientation

Discharge Assembly Check Valve

Background

Data taken at installation sites have shown better performance in the discharge piping when the check valve is installed on the outlet of a 45 degree elbow as opposed to the 90 degree elbow provided as part of the installation kit.

- With the check valve to be positioned vertically, any solids not completely dissolved can deposit easily within the check valve components when there is no suction.

Orienting the check valve at a 45 degree angle decreases backpressure in the suction line and increases venturi performance.

Check Valve Installation at Venturi End of Discharge Tubing

Installing the check valve at the venturi end of the discharge tubing also improves maintenance by reducing solids build up at the outlet of the feeder and in the check valve.

Optional Check Valve Installation

Sites that have the **Pulsar**® Booster Pump set to “Always On” have the option not to install the check valve at all. This dramatically improves flow rate and reduces maintenance and cleaning requirements.



figure 1



figure 2

Appendix C – Pulsar CRS™ System Upgrades

Pulsar CRS™ System Upgrade

Part Number	Description	Quantity
79620	Pulsar CRS™ PCP Installation Kit	
79621	Pulsar CRS™ PCP Pump	x1
79622	Pulsar CRS™ PCP Pump Mounting Kit	x1
79608	Pulsar® 1/4" NPT Cord Grip for Flow Switch Cable	x2
79609	Pulsar CRS™ Flow Switch Cable	x1
79669	Pulsar® Flow Switch	x1

Description of System Upgrade

This system is an upgrade to the previously released **Pulsar CRS™** System. It integrates into the new **Pulsar®** control panel and eliminates the complexity of programming an external timer, improving system efficiency.

- Feed timer controlled by **Pulsar®** control panel
- Feed based on exact pool size
- Feed clarifier only when needed based on actual backwash
- Automatically feed clarifier after backwash
- Improve clarification of pool water for sand filtered pools

This new installation of the **Pulsar CRS™** System utilizes the ECON FP pump by Stenner Pumps. It is a peristaltic pump, mounted above the **Pulsar CRS™** System chemical reservoir (55 gallon drum or 5 gallon bucket) and connected to an external outlet for power, and the blue terminal blocks inside of the control panel. The control panel

uses a second flow switch, included in the **Pulsar CRS™** PCP Installation Kit (79620). When the control panel senses a backwash flow of at least ten seconds, it triggers an event timer which will turn on the pump 30 minutes after the backwash flow has stopped. The 30 minute delay is to ensure that all maintenance is completed and that the pool is back into normal filtration mode. If another backwash event is sensed during the 30 minute delay, then the timer does reset back to 30 minutes. The timer is designed to slowly pump in one ounce per 5,000 gallons, which is equivalent to 1 minute per 1,000 gallons, based on the ECON FP pump by Stenner Pumps. This will generate an even coating of clarifier across the sand filter bed to remove additional contaminants from your pool water. Be aware that after the first application or two, you will need to backwash more frequently due to the enhanced filtration achieved by the **Pulsar CRS™** Clarifier. Also note the increased turbidity of your backwash water. This is also due to the enhanced filtration generated by the **Pulsar CRS™** Clarifier.

Appendix C – Pulsar CRS™ System Upgrades

Tools & Equipment Needed for Install:

Adjustable Wrench for 1/2” nut

Drill bits – 7/16” and 23/32” for drill and tapping

Thread taps for 1/4” and 1/2” pipe threads

Wire cutters and wire strippers for 22AWG wire

Phillips screwdriver

Precision straight slot screwdriver 2.5 x 0.4mm and a 3.5 x 0.5mm blade

Installation Instructions

1. Ensure that backwash is turned off. Drill and tap a 1/2” hole on the bottom side of the backwash pipe. Thread tape the flow switch and thread into backwash line. This will be the sensor for automating the **Pulsar CRS™** System (figure 1).

For Steps 2-7, see Figure 2.

2. Turn off the **Pulsar®** control panel and unplug it from the wall outlet. You will need to drill one or two holes, depending on the number of open penetrations available in your control panel. These holes will be used for: 1) Orange Flow Switch cable, and 2) Gray signal cable from the Stenner Pump. Install the cord grips as shown.
3. Once the penetrations are made and the cord grips have been installed. Thread the cords as shown. The orange cord should be landed to either the gray terminal blocks on the bottom row, if available, or directly to the PLC on the back of the panel door. If you have one plugged penetration in the panel, you will only drill one hole and will land the Orange Flow Switch Cable to the gray terminal blocks. If you must make two penetrations, then you will have to land the Orange Flow Switch Cable directly to the back of the PLC as shown.



figure 1



figure 2

Appendix C – Pulsar CRS™ System Upgrades

4. If you do not have the extra gray terminal blocks, the Orange Flow Switch Cable should be landed as follows:

- a. Blue Wire lands to a spare opening in Terminal Block 2 (next to motor starter on top row)
- b. Brown Wire lands to a spare opening in Terminal Block 1 (next to the power supply on top row)
- c. Black Wire lands to Input I7 on the PLC directly.
- d. The White Wire is not used (*figure 3*).

5. If you have the extra gray terminal blocks: the Orange Flow Switch Cable land the cables in the order of Blue, Black, Brown from left to right, on terminal blocks, 3, 4, 5 respectively. The white wire is not used.

6. The Gray Pump Signal Cable should be landed on the Blue Terminal Blocks on the bottom row inside the **Pulsar®** control panel. Use the colors.

7. Tighten the cord grip nuts around the cables to ensure that they will not move and put strain on the landed wires.

8. Set up the chemical in a nearby location, such that the pump can be mounted above it.

9. Mount the Stenner Econ FP pump mount as shown (*figure 4*).

10. Plug the 10 foot power cable of the Stenner Econ FP pump into a NEMA 5-15 outlet to power on the pump as shown (*figure 5*).

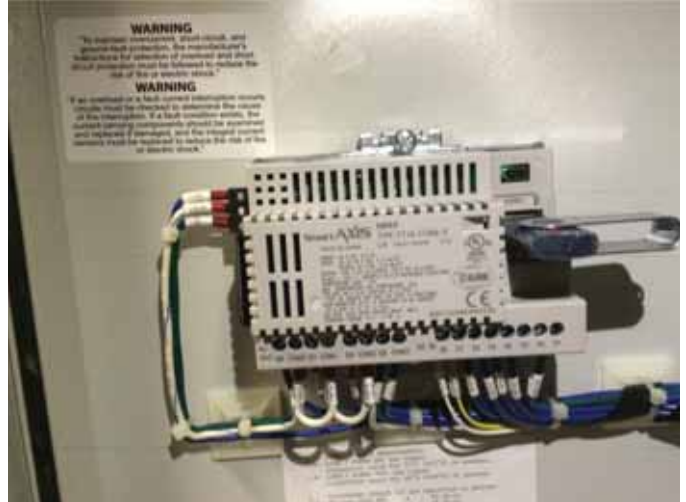

figure 3



figure 4



figure 5

Appendix C – Pulsar CRS™ System Upgrades

11. Program the Stenner Econ FP pump per the Stenner Pumps manual using the following settings.
 - e. Unscrew the cover plate set screw
 - f. Remove the cover and unlock the keypad by pressing and holding 'MODE' and %simultaneously for 5 seconds.
 - g. Set the signal type to flow switch by pressing and holding 'MODE' then the 'UP' or 'DOWN' arrow to scroll through the Modes.
 - h. Set the output to 100% by pressing and holding & then the 'UP' arrow.
 - i. Turn the keypad off STANDBY by pressing the 'STBY' button once.
 - j. Replace the cover and set screw.

12. Land the Black and Red Wires on the blue terminal blocks on the bottom rail inside the **Pulsar**® control panel (*figure 2, page 45*).

13. Hook up the suction and discharge of the Stenner pump per the Stenner installation manual (*figure 6*).

14. Follow the **Pulsar CRS**™ System Specific Programming Instructions for programming the pool size and complete setup.



figure 6

Appendix D – Pulsar® Cable Length Guide to Control Panel

Cable Length Guide

Background and Purpose

This technical bulletin is to call out the exact cable lengths and part numbers that are recommended by Lonza for extending the flow switch signal cable, manufactured by IFM Efector, and the feeder control cable, manufactured by Turck.

Recommendation

The recommendation for extending the cable, for either situation, is to purchase the “patch cable” style, which is like an extension cable, and requires no wiring internally in the **Pulsar®** Control Panel or **Pulsar®** Feeder Junction Box.

Flow Switch Extension Cable

- Part Number 79663, **Pulsar®** Flow Switch Extension Cable (10 meters)
- Orange PVC sheath
- Current PCP Cable (printed on cable near plug end): EVT001 – 5 meters, or EVT002 – 10 meters.
- Maximum manufacturer-approved length for unshielded cable for flow switch is 10 meters.
- Running cables beyond the 10 meter limit must be shielded and run away from large electrical sources, including HVAC systems and pump motors.

Feeder Control Extension Cable

- Part Number 79662, **Pulsar®** Turck Extension Cable (5 meters)
- Gray PVC sheath
- Feeder Control Cable



Flow Switch Cable



Feeder Control Cable

Appendix E – ORP Leakage Current Tech Bulletin

Personal Protective Equipment and Parts Needed

Safety



Leather Gloves



Safety Glasses

Tools



Wire Cutters

Background

The **Pulsar**[®] Control Panel ORP interface relay is an electro-mechanical relay which has a very low amperage requirement for holding in the coil once energized. Some ORP controllers use solid state relays which have an inherent leakage current when not actively energized. This leakage current may keep the ORP relay inside of the **Pulsar**[®] Control Panel active, and thus continually feeding, even when the ORP is not calling for chlorine. To date, there have been two specific brands of controllers that have caused this type of failure, based on feedback from the field: ChemTrol brand programmable controllers, and BECSys controllers.

Chemtrol Programmable Controllers

The PC3000/ PC2000 leak voltage as you know and have seen. The voltage leak comes through the RF network across the points on either side of the relays.

You will want to clip either side of all the 100 ohm resistors for each relay that activates a valve. So, on the OXY relay it will be R86, R87, R88, and R89. For the Sanitizer, it will be R92, R93, R94, and R95. Again you will clip one leg from each side and pull it away from the board so you could re solder it if you needed to. For further information, please contact Chemtrol directly at www.sbcontrol.com, or toll Free at 800-621-2279.

BECSys Controllers : Operating a Contactor Using a Solid State Relay

There have been applications where Contactors (relays used to switch a large amount of electrical power through their contacts) connected to a solid state relay on a BECSys controller will not turn off when the controller indicates that the relay should de-energize. A Contactor requires more current to start up than it does to maintain its “ON” state (drop-out current). Solid state relays have some leakage current associated with them which may be enough to continue operating the Contactor even after the controller has signaled the relay to turn off.

Using a 33k Ohm, 2 Watt resistor (8120621) will bleed approximately 3.6 milliamps of current from the relay output (assuming the load is operated at 120VAC). Adding this resistor in parallel with the Contactor should take enough of the leakage current to allow the Contactor to shut off. This bleed resistor can be installed either at the Contactor or inside the controller, whichever is most convenient. If the resistor is being installed inside the controller, then connect one lead of the resistor to the solid state relay’s normally open (NO) terminal and the other lead to the corresponding neutral (N) terminal. The example (*page 50*) shows a bleed resistor installed for a Contactor connected to Relay1 in a BECSys7 controller.

Appendix E – ORP Leakage Current Tech Bulletin

WARNING! All power must be removed from the system before installation of the bleed resistor.

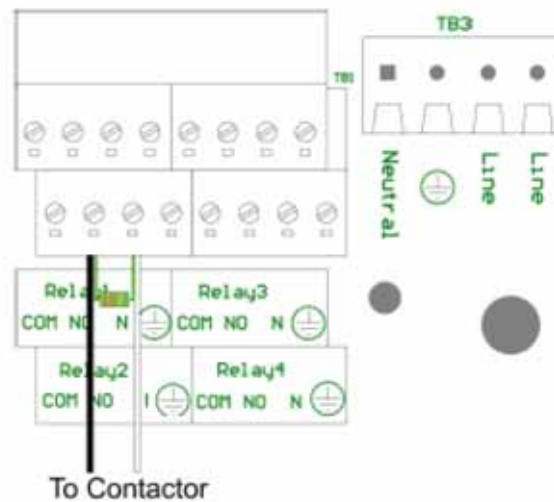

Part Number	Description
8120621	33K ohm Carbon Film 2W Resistor 5%

Disclaimer and Limitation of Liability

This document is provided to you (“Recipient”) by Arch Chemicals, Inc. or one of its affiliate companies (“Lonza”) for information purposes only, and is not intended to and does not constitute part of any product specification. It is only an overview for industry professionals of certain information with respect to the product; always read all product information (including but not limited to the product label, MSDS and product information sheets, hereafter referred to as “Product Information”) before use. All Product Information corresponds to Lonza’s knowledge on the subject at the date of publication and Lonza assumes no obligation to update it. Product Information is intended for use by Recipients experienced and knowledgeable in the field, who are capable of and responsible for determining independently the suitability of Product Information for their specific applications.

THIS PRODUCT INFORMATION IS OFFERED IN GOOD FAITH AND WITHOUT WARRANTY, EITHER EXPRESSED OR IMPLIED, REGARDING ITS ACCURACY OR THE RESULTS TO BE OBTAINED FROM THE USE OF SUCH INFORMATION. ANY ADDITIONAL WARRANTIES, EXPRESS OR IMPLIED, ARE HEREBY DISCLAIMED. Lonza’s total liability and Recipient’s exclusive remedy for any cause of action associated with any technical advice, service, recommendation made or Product Information provided, howsoever caused and whether based in tort, contract, strict liability or any other legal theory, is expressly limited to the amount paid directly for such advice, service, recommendation or Product Information for which damages are claimed. In no event shall Lonza be liable for any other damages including, without limitation, any indirect, consequential, incidental, special or punitive damages.

Warranty Policy

Pulsar® 500 Feeder

Lonza warrants equipment (excluding electrical components) of its manufacture and bearing its identification to be free of defects in workmanship and material. Lonza's liability under this warranty extends for a period of two (2) years from the date of installation as performed by an Authorized Commercial Dealer Representative and registered with Lonza Water Chemicals via the Lonza Commercial Chlorinator Warranty Registration Card. Systems for which there is no Warranty Registration Card on file carry no warranty of any kind, expressed or implied.

In addition, each system is covered by a sixty (60) -day, 100% buy-back guarantee. If the original purchaser ("owner") is dissatisfied with the **Pulsar® 500 Feeder** performance for any reason, they can return it to the Authorized Commercial Pool Dealer for a full refund. The equipment must have received normal use and care, and Lonza must be notified in writing before the sixty (60) days have expired. There is no reimbursement for chemicals used during the sixty (60) -days.

Lonza disclaims all liability for damage during transportation, for consequential damage of whatever nature, for damage due to handling, installation or improper operation, and for determined suitability for the use intended by purchaser ("owner"). Lonza make no warranties, either expressed or implied, other than those stated above. No Lonza Representative or Authorized Commercial Dealer Representative has authority to change or modify this warranty in any respect.

Pulsar® 500 Parts

Lonza warrants equipment parts of its manufacture and bearing its identification to be free of defects in workmanship and material. Lonza's liability under this warranty extends for a period of ninety (90) days from the date of installation as performed by an Authorized Commercial Dealer Representative. This warranty is restricted to **Pulsar® 500 Feeder** parts purchased on a replacement basis.

Lonza

1200 Bluegrass Lakes Parkway
Alpharetta GA, 30004
1-800-4-PULSAR

Lonza

Lonza Emergency Action Network (LEAN)

Emergency Contact Information

The Lonza Emergency Action Network (“LEAN”) is Lonza’s emergency action system. Call the LEAN system at 1-800-654-6911 in North America, and at 1-423-780-2970 elsewhere in the world to reach the International Emergency Hotline. The LEAN system is available 24 hours a day, 7 days a week for assistance with spills, injuries and emergencies of any kind. It uses computers and other systems to make Lonza’s environmental, technical transportation, toxicological and other expertise about its products readily available to anyone needing assistance.

1-800-654-6911

(Outside North America, call 1-423-780-2970, International Emergency Hotline)

Additionally, in the event of an emergency, CHEMTREC (Chemical Transportation Emergency Center) should be contacted. CHEMTREC is a national center established by the Chemical Manufacturers Association (CMA) in Washington, DC, to relay pertinent emergency information concerning specific chemicals on request.

CHEMTREC has a 24-hour toll-free telephone number intended primarily for use by those who respond to chemical transportation emergencies, 1-800-424-9300 in North America, and at 1-703-527-3887 elsewhere in the world. CHEMTREC may also be accessed through the CMA website at www.cmahq.com.

Safety Data Sheets (SDS) can be obtained by contacting the following number: 1-800-511-MSDS in North America, and at 1-423-780-2347 elsewhere in the world.

